

YH 00528

EXPERIMENTS
IN
AERODYNAMICS

BY
S. P. LANGLEY



LIBRARY
OF THE
UNIVERSITY OF CALIFORNIA.

GIFT OF

Smithsonian Institution.

Accession 103711 Class

SMITHSONIAN CONTRIBUTIONS TO KNOWLEDGE.

801

EXPERIMENTS
IN
AERODYNAMICS.

BY

S. P. LANGLEY.

SECOND EDITION.

(First Edition Published in 1891.)



CITY OF WASHINGTON :
PUBLISHED BY THE SMITHSONIAN INSTITUTION
1902.

FEB 24 1900

FTL570
L3
1902

COMMISSION TO WHOM THIS MEMOIR HAS BEEN REFERRED.

Professor SIMON NEWCOMB, U. S. N.

Professor HENRY A. ROWLAND.

Professor CLEVELAND ABBE.

Dept of S. Institution

PREFACE TO THE FIRST EDITION.

If there prove to be anything of permanent value in these investigations, I desire that they may be remembered in connection with the name of the late William Thaw, whose generosity provided the principal means for them.

I have to thank the board of direction of the Bache fund of the National Academy of Sciences for their aid, and also the trustees of the Western University of Pennsylvania for their permission to use the means of the observatory under their charge in contributing to the same end, and I desire to acknowledge especially the constant and valued help of Mr. Frank W. Very, who has assisted me in all these experiments, and my further obligation to Mr. George E. Curtis, who has most efficiently aided me in the final computations and reductions.

S. P. LANGLEY.

SMITHSONIAN INSTITUTION,
WASHINGTON, 1891.

PREFACE TO THE SECOND EDITION.

The first edition of this work being exhausted, a second is now published, in which, however, little is added to the subject matter already printed, for though a description of the construction here of heavy flying machines mostly built of steel, which have flown long distances, is already prepared, it has not been considered best to publish the details at present. In the meantime, the fact that such machines, made on the principles and in the light of the experiments first shown in this book, have since actually flown (See Comptes Rendus, t. CXXII, Seance 26 Mai, 1896; Nature, Vol. 54, May 28, 1896.) will give, it is hoped, an additional weight and interest to the statements in the present volume.

S. P. LANGLEY.

SMITHSONIAN INSTITUTION,
WASHINGTON, APRIL, 1902.

CONTENTS.

PREFACE	1
CHAPTER I.—Introductory	3
II.—Character and Method of Experiments	7
III.—The Suspended Plane	12
IV.—The Resultant Pressure Recorder	15
V.—The Plane-Dropper	26
VI.—The Component Pressure Recorder	48
VII.—The Dynamometer-Chronograph	75
VIII.—The Counterpoised Eccentric Plane	89
IX.—The Rolling Carriage	94
X.—Summary	105
Appendix A	109
Appendix B	113
Appendix C	114



CHAPTER I.

INTRODUCTORY.

Schemes for mechanical flight have been so generally associated in the past with other methods than those of science, that it is commonly supposed the long record of failures has left such practical demonstration of the futility of all such hopes for the future that no one of scientific training will be found to give them countenance. While recognizing that this view is a natural one, I have, however, during some years, devoted nearly all the time at my command for research, if not directly to this purpose, yet to one cognate to it, with a result which I feel ought now to be made public.

To prevent misapprehension, let me state at the outset that I do not undertake to explain any art of mechanical flight, but to demonstrate experimentally certain propositions in aerodynamics which prove that such flight under proper direction is practicable. This being understood, I may state that these researches have led to the result that mechanical sustentation of heavy bodies in the air, combined with very great speeds, is not only possible, but within the reach of mechanical means we actually possess, and that while these researches are, as I have said, not meant to demonstrate the art of guiding such heavy bodies in flight, they do show that we now have the power to sustain and propel them.

Further than this, these new experiments, (and theory also when reviewed in their light,) show that if in such aerial motion, there be given a plane of fixed size and weight, inclined at such an angle, and moved forward at such a speed, that it shall be sustained in horizontal flight, then the more rapid the motion is, the *less* will be the power required to support and advance it. This statement may, I am aware, present an appearance so paradoxical that the reader may ask himself if he has rightly understood it. To make the meaning quite indubitable, let me repeat it in another form, and say that these experiments show that a definite amount of power so expended at any constant rate, will attain more economical results at high speeds than at low ones—*e. g.*, one horse-power thus employed, will transport a larger weight at 20 miles an hour than at 10, a still larger at 40 miles than at 20, and so on, with an increasing economy of power with each higher speed, up to some remote limit not yet attained in experiment, but probably represented by higher speeds than have as yet been reached in any other mode of transport—a statement which demands and will receive the amplest confirmation later in these pages.

I have now been engaged since the beginning of the year 1887 in experiments on an extended scale for determining the possibility of, and the conditions for, transporting in the air a body whose specific gravity is greater than that of the air, and I desire to repeat my conviction that the obstacles in its way are not such as have been thought; that they lie more in such apparently secondary difficulties as those of guiding the body so that it may move in the direction desired, and ascend or descend with safety, than in what may appear to be the primary difficulties due to the nature of the air itself, and that in my opinion the evidence for this is now sufficiently complete to engage the serious attention of engineers to the practical solution of these secondary difficulties, and to the development of an art of mechanical flight which will bring with it a change in many of the conditions of individual and national existence whose importance can hardly be estimated.

The way to this has not been pointed out by established treatises on aerodynamics, whose fundamental postulates, like those of any other established science, may be held to contain implicitly all truths deducible from them, but which are so far from being of practical help here, that from these postulates previous writers of the highest repute have deduced the directly opposite conclusion, that mechanical flight is practically impossible.* Reason unaided by new experiment, then, has done little or nothing in favor of the view now taken.

It may be asked whether it is not otherwise with statements which are authorized by such names as that of Newton, and whether a knowledge of truths mathematically deducible from them, would not at any rate furnish a test to distinguish the probably true from the probably false; but here it is important to remember that the mathematical method as applied to physics, must always be trustworthy or untrustworthy, according to the trustworthiness of the data which are employed; that the most complete presentation of symbols and processes will only serve to enlarge the consequence of error hidden in the original premises, if such there be, and that here, as will be shown, the error as to fact begins with the great name of Newton himself.

In this untrodden field of research, which looks to mechanical flight, not by means of balloons, but by bodies specifically heavier than the air in which they move, I think it safe to say that we are still, at the time this is written, in a relatively less advanced condition than the study of steam was before the time of Newcomen; and if we remember that such statements as have been commonly made with reference to this, till lately are, with rare exceptions, the product of conjecture rather than of study and experiment, we may better see that there is here as yet, no rule to distinguish the probably important from the probably unimportant, such as we command in publications devoted to the progress of already established sciences.

*See paper by Gay-Lussac and Navier, cited later.

There is an excellent custom among scientific investigators, of prefacing the account of each new research with an abstract of the work of those who have already presumably advanced knowledge in the science in question; but in this case, where almost nothing is established, I have found hardly any test but that of experiment to distinguish between those suggestions presumably worth citation and attention and those which are not. Since, then, it is usually only after the experiments which are later to be described have been made, that we can distinguish in retrospective examination what would have been useful to the investigator if he could have appreciated its true character without this test, I have deferred the task of giving a résumé of the literature of the subject until it could be done in the light of acquired knowledge.

I have thus been led to give the time which I could dispose of, so exclusively to experiment, that it may well be that I have missed the knowledge of some recent researches of value; and if this be so, I desire that the absence of mention of them in the present publication, may be taken as the result, not of design, but of an ignorance, which I shall hope, in such case, to repair in a later publication; while, among the few earlier memoirs that I am conscious of owing much useful suggestion to, it is just that I should mention a remarkable one by Mr. Wenham, which appeared in the first number of the London Aeronautical Society's report, 24 years ago, and some by Penaud in *L' Aeronauté*.

The reader, especially if he be himself skilled in observation, may perhaps be willing to agree that since there is here so little yet established, so great a variety of tentative experiments must be made, that it is impossible to give each of them at the outset all the degree of accuracy which is ultimately desirable, and that he may yet find all trustworthy within the limits of their present application.

I do not, then, offer here a treatise on aerodynamics, but an experimental demonstration that we already possess in the steam-engine as now constructed, or in other heat engines, more than the requisite power to urge a system of rigid planes through the air at a great velocity, making them not only self-sustaining, but capable of carrying other than their own weight. This is not asserting that they can be steadily and securely *guided* through the air, or safely brought to the ground without shock, or even that the plane itself is the best form of surface for support; all these are practical considerations of quite another order, belonging to the yet inchoate art of constructing suitable mechanisms for guiding heavy bodies through the air on the principles indicated, and which art (to refer to it by some title distinct from any associated with ballooning) I will provisionally call *aerodromics*.* With respect to this inchoate art, I desire to be understood as not here offering any direct evidence, or

* From *ἀεροδρομῆω*, to traverse the air; *ἀεροδρόμιος*, an air-runner.

expressing any opinion other than may be implied in the very description of these experiments themselves.

It is just to say, finally, in regard to the extreme length of time (four years) which these experiments may appear to have taken, that, beyond the fact of their being in an entirely new field, nearly all imply a great amount of previous trial and failure, which has not been obtruded on the reader, except to point out sources of wasted effort which future investigators may thus be spared, and that they have been made in the intervals of quite other occupations, connected with administrative duties in another city.

CHAPTER II.

CHARACTER AND METHOD OF EXPERIMENTS.

The experiments which I have devised and here describe, are made with one specific object, namely, to elucidate the dynamic principles lying at the basis of the aerial mechanical flight of bodies denser than the air in which they move, and I have refrained as a rule from all collateral investigations, however important, not contributing to this end. These experiments, then, are in no way concerned with ordinary aeronautics, or the use of balloons, or objects lighter than the air, but solely with the mechanical sustentation of bodies denser than the air, and the reader will please note that only the latter are referred to throughout this memoir when such expressions as "planes," "models," "mechanical flight," and the like, are used.

The experiments in question, for obtaining first approximations to the power and velocities needed to sustain in the air such heavy inclined planes or other models in rapid movement, have been principally made with a very large whirling table, located on the grounds of the Allegheny Observatory, Allegheny, Pa. (lat. $40^{\circ} 27' 41.6''$; long. $5^{\text{h}} 20^{\text{m}} 2.93^{\text{s}}$; height above the sea-level, 1,145 feet).

The site is a hill on the north of the valley of the Ohio and rising about 400 feet above it. At the time of these observations the hill-top was bare of trees and of buildings, except those of the observatory itself. This hill-top is a plane of about three acres, of which the observatory occupies the south side. The ground slopes rapidly both toward the east and west, the latter being the quarter from which come the prevailing winds.

The general disposition of the grounds of the observatory buildings, of the engine, and of the whirling table is shown in plate I. The whirling table is shown in plate II, in elevation and in plan, and with details on an enlarged scale. It has been constructed especially in view of the need of getting the greatest continuous speed thus attainable, under circumstances which should render corrections for the effects of circular motion negligible, in relation to the degree of accuracy aimed at.

The first disturbing effect of circular motion to present itself to the mind of the reader will probably be centrifugal force; but in regard to this he may observe that in all the pieces of apparatus hereafter to be described, the various parts are so disposed that the centrifugal force proper, viz., the outward thrust of the plane

or model which is the subject of experiment, shall not disturb or vitiate the quantitative data which are sought to be obtained.

On the other hand, the effects of circular motion, as regards the behavior of the air in its enforced circulation, are only to be obtained, as I believe, empirically, and by very elaborate experiments; the formulæ that are likely to present themselves to the reader's mind for this computation, largely involving the very errors of fact which the experiments here described are meant to correct. This class of corrections is, then, only approximately calculable, and we have to diminish their importance by the use of so large a circle that the motion can be treated as (for our purpose) linear. To show that these corrections are negligible in relation to such degree of accuracy as we seek, we may advantageously consider such a numerical example as will present the maximum error of this sort that obtains under the most unfavorable circumstances.

Let this example be the use of a plane of the greatest length hereafter described in these experiments, viz., 30 inches, and let us suppose its center to be at the end of a revolving arm 30 feet in length, which was that employed.

Let us suppose the plane to be so disposed as to cause the effect of the inequality of air resistance arising from the circular motion to be a maximum, which will presumably be the case if it is placed parallel to the arm of the whirling table, so that there is also presumably the greatest possible difference between the pressure on the outer and the inner half. Under these circumstances it is assumed in the experiments detailed in the following chapters, that the whole plane may be treated as moving with the linear velocity of its center, and it will be now shown that this assumption is permissible. The portions of the plane as we proceed outward from the center, are exposed, on the whole, to a greater pressure, and as we proceed inward to the center to a less. Using, in the absence of any wholly satisfactory assumption, the well-known one implicitly given by Newton in the Principia, that the pressure of the air at every point of the plane is strictly proportional to the square of the velocity with which it is moving (thereby neglecting the secondary effect of the mutual action of the stream lines on each other), the pressure at the inner end of the plane is proportional to $(28\frac{1}{2})^2 = 826.6$; at the outer end to $(31\frac{1}{2})^2 = 976.6$, and at the center to $(30)^2 = 900$. The mean of these pressures at the inner and outer ends, viz., 901.6, differs from the pressure at the center by 1.6, or less than one-fifth of one per cent, and *a fortiori* the integrated pressure over the whole area in this and still smaller planes, differs from the pressure computed with the velocity at the center, by less than the same amount. The example will, it is hoped, make it sufficiently clear that such disturbing effects of air-pressure arising from circular motion, are for our purposes negligible, and the precautions taken against other detrimental effects, will be evident from a consideration of the disposition of the apparatus employed in each case.

Most of the various experiments which I have executed involve measurements of the pressure of air on moving planes,* and the quantitative pressures obtaining in all of these experiments are of such magnitude that the friction of the air is inappreciable in comparison. This fact may be stated as the result, both of my own experiments (which are here only indirectly presented) and of well-known experiments of others.† It will be seen that my experiments implicitly show that the effect of friction on the surfaces and at the speeds considered is negligible, and that in them I have treated the actual air-pressure as being for practical purposes normal to the surface, as in the case of an ideal fluid.

The whirling table consists essentially of two symmetrical wooden arms, each 30 feet (9.15 meters) long, revolving in a plane eight feet above the ground. Each arm is formed of two continuous parallel strips united by struts as shown in the plate, and is made at once broad and thin, so as to possess the requisite lateral strength, while opposing as little resistance to the air as possible, its vertical rigidity being increased by guys. The arms are accordingly supported by iron wires extending from a point in the axis about 8 feet (2.5 meters) above the table. An enlarged section of the lower end of the axis is given in the plate, showing the lower bearing and the position of the bevel-wheels connected with the shaft, which is driven by the engine. A lever is also shown, by means of which the table may be lifted out of its gearing and revolved by hand. The gearing is so disposed that the direction of rotation is always positive—*i. e.*, clockwise to one looking down on it. The whirling table was driven first by a gas-engine of about $1\frac{1}{2}$ horse-power, but it was found inadequate to do the work required, and, after October 20, 1888, a steam-engine giving 10 horse-power was used in its stead. This was a portable engine of 10-inch stroke, having a fly-wheel giving from 60 to 150 revolutions per minute, but ordinarily run at about 120 revolutions, with 90 pounds of steam. The belt of either engine communicates its motion to a set of step-pulleys, by means of which four different velocity-ratios can be obtained. These pulleys turn a horizontal shaft running underground to the axis of the turn-table, as indicated on the ground plan of the engine-house at A, and also

* Since it is impossible to construct absolutely plane surfaces at once very thin and very rigid, those "planes" in actual use have been modified as hereafter described. They have all, however, it will be observed, square and not rounded edges, and it should be likewise observed that the values thus obtained, while more exactly calculable, give less favorable results than if the edges were rounded, or than if the section of the plane were such as to give "stream lines."

† There is now, I believe, substantial agreement in the view that ordinarily there is no slipping of a fluid past the surface of a solid, but that a film of air adheres to the surface, and that the friction experienced is largely the internal friction of the fluid—*i. e.*, the viscosity. Perhaps the best formula embodying the latter is given by Clerk Maxwell in his investigation on the coefficient of the viscosity of the air. This is $\mu = 0.0001878 (1 + .0027 \theta)$, μ and θ being taken as defined in his paper on the dynamical theory of gases in *Phil. Trans.*, Vol. CLVII. By this formula the actual tangential force on a one-foot-square plane moving parallel to itself through the air at the rate of 100 feet a second is 1,095 dynes (0.08 poundals), or less than $\frac{1}{30}$ of 1 per cent. of the pressure on the same plane moving normally at this speed, and hence theory as well as observation shows its negligibility.

on the elevation at A', where it is shown as geared to this vertical axis by a pair of bevel-wheels, that of the shaft having 15 teeth and that of the turn-table axis having 75 teeth, or 1 to 5. The cone-pulleys used from the beginning of the experiments up to September, 1890, have four steps with diameters of $21\frac{1}{2}$, $18\frac{1}{2}$, $11\frac{1}{2}$, and 8 inches. The speeds given by these pulleys in terms of whirling-table revolutions for 1,000 revolutions of the gas-engine are approximately—

Lowest speed.....	25
Second “	50
Third “	100
Highest “	200

The gas-engine speed varied from 180 to 190 revolutions per minute.

In September, 1890, the above-described pulleys were replaced by a larger set of three steps, having diameters of 36, $25\frac{1}{2}$ and 18 inches, respectively, which give speeds in the ratio of 4, 2, and 1, and the gear, which had broken, was replaced by a new one of 1 to 4.

This system gives for 120 revolutions of the steam-engine per minute, driving—

18 in. pulley, 48 revolutions of turn-table per minute	= 100 + miles per hour at end of arm.
$25\frac{1}{2}$ “ “ 24 “ “ “	= 50 + “ “ “ “
36 “ “ 12 “ “ “	= 25 + “ “ “ “

By regulating the speed of the engine any intermediate velocities can be obtained, and thus the equipment should be susceptible of furnishing speeds from 10 to 100 miles per hour (4.5 to 45 meters per second); but owing to the slipping of belts the number of turn-table revolutions was less than this for the higher velocities, so that the highest attained in the experiments did not reach this upper limit, but was a little over 100 feet (30 meters) per second, or about seventy miles per hour. The precise velocity actually attained by the turn-table is determined, quite independently of the speed of the engine, by an electrical registration on the standard chronograph in the observatory. The electrical current passes into four fixed contact-pieces (shown at O-P, plate II, and on large scale in plate III) fastened to a fixed block placed around the axis of the whirling table, these fixed pieces being placed symmetrically around the axis, while another platinum contact-piece is fastened to a horizontal arm screwed into the axis of the turn-table and revolving with it, thus “making circuit” every quarter revolution of the table. The current passes out of the axis through a brush contact, shown in plate III, and thence to the chronograph in the observatory. C designates the fixed contact pieces, and P the platinum piece revolving with the axis. S and L are adjusting screws. Turning again to plate II, an additional brush contact, shown at B, and again at B', serves to transmit

a current to wires running out to the end of the whirling arm, so that seconds from the mean time clock and other phenomena can be registered on the recording cylinder of the dynamometer chronograph at the end of the arm; and also phenomena taking place at the end of the arm can be registered on the chronograph in the observatory. By these means the experiments are put under electric control and perfect knowledge is obtained of the velocity of the turntable at the moment when any phenomenon occurs. This brush contact was made sufficiently large and heavy to transmit a current from a dynamo to an electric motor placed on the whirling arm, and, having this electric equipment extending to the outer end of the whirling arm, different pieces of apparatus were devised for registering pressure and other phenomena there.

The whirling table was thus established and the experiments conducted in the open air, not through choice, but because the erection of a large building specially designed for them was too expensive to be practicable. It was hoped to take advantage of calm days for the performance of experiments, as in a calm, a whirling table in the open air is under the best possible conditions, for in a confined building the rotating arm itself sets all the air of the room into slow movement, besides creating eddies which do not promptly dissipate. Practically, however, these calm days almost never came, and the presence of wind currents continued from the beginning to the end of the experiments, to be a source of delay beyond all anticipation, as well as of frequent failure.

In the latter part of April, 1889, an octagon fence 20 feet high (shown on plate I) was erected around the whirling table with the object of cutting off, to some extent, the access of the wind. This, however, proved to be ineffectual, and the difficulty experienced from the wind continued nearly unabated.

If any one should propose to repeat or extend these experiments, I would advise him, first of all, and at all costs, to establish his whirling table in a large, completely inclosed building.

CHAPTER III.

THE SUSPENDED PLANE.

The first instrument, called the *Suspended Plane*, was devised to illustrate an unfamiliar application of a known principle. I call the application "unfamiliar" because distinguished physicists have held, for instance, that a bird (which obviously expends a certain amount of muscular effort in simply hovering in the air) must expend in flight all the effort required for hovering, together with so much additional energy as is required to overcome the resistance of the air to its horizontal motion, so that the energy expended increases with the velocity attained,* while the consideration of the action of the suspended plane indicates, if it do not demonstrate, that the opposite view is the true one, and thus serves as a useful introduction to the demonstrative experiments I have spoken of as coming later.

* This view of flight received indorsement from a source of the highest authority in a report by Gay-Lussac, Flourens, and Navier, accepted and published by the Institute of France in 1830. [Navier, C. L. M. II.—Rapport sur un Mémoire de M. Chabrier concernant les moyens de voyager dans l'air et de s'y diriger, contenant une nouvelle théorie des mouvements progressifs. (Commissaires, MM. Gay-Lussac, Flourens, et Navier, rapporteur.) Paris, Mém. Acad. Sci. xi, 1832 (Hist.), pp. 61-118.] The report is drawn up by Navier, to whom the mathematical investigation is due. He formulates the differential equations of motion for the two cases of hovering and horizontal flight, integrates them in the customary way, assumes approximate values for the constants of the equations, and computes the work expended by an ordinary swallow with the following results: For hovering, the work done per second by the swallow is approximately equal to the work required to raise its own weight eight meters. While in horizontal flight the work done varies as the cube of the velocity, and for 15 meters per second is equal to 5.95 kilogrammeters per second, or enough to raise its weight 390 meters. This is *fifty times* as much as that expended in hovering, or in English measures, over 2,500 foot-pounds per minute, which is a rate of working greater than a man has when lifting earth with a spade.

The same computation applies to any larger bird whose weight bears the same ratio to the extent of its wings. In view of these figures Navier suggests that *there exists the same ratio between the efforts necessary for simple suspension and for rapid flight as exists for terrestrial animals between the effort required for standing upright and that required for running.* [Nous remarquerons la grande différence qui existe entre la force nécessaire pour que l'oiseau se soutienne simplement dans l'air, et celle qu'exige un mouvement rapide. Lorsque la vitesse de ce mouvement est de 15^m par seconde, on trouve que cette dernière force est environ *cinquante fois* plus grande que la première. Ainsi l'effort qu'exerce l'oiseau pour se soutenir dans l'air est fort petit comparativement à l'effort qu'il exerce dans le vol. Il en coûte peut-être moins de fatigue à l'oiseau pour se soutenir simplement dans l'air, eu égard à la fatigue qu'il est capable de supporter, qu'il n'en coûte à l'homme et aux quadrupèdes pour se soutenir debout sur leurs jambes."—Paris, Mém. Acad. Sci. xi, 1832 (Hist.), p. 71.] The supposed elegance and validity of Navier's mathematical processes, and especially the elaboration with which they were carried out, appears to have obscured the absolutely inadmissible character of these results, and they received the unqualified adherence of the remainder of the committee. This report thereupon became a standard authority upon the theory of flight, and continued to be so accepted for many years.

The *suspended plane* (plate IV) consists of a thin brass plane one foot square, weighing two pounds, hung vertically by a spring from a surrounding frame. Eight delicate friction rollers AA', BB' enable the plane to move freely along the frame, but prevent any twisting or lateral motion, the use of the guide-frame being to prevent the plane from so "flouncing" under irregular air currents that its pull cannot be measured. The guide-frame carrying the plane turns symmetrically about an axis, CC', so that the gravity-moment about the axis is simply the weight of the plane on a lever arm measured from its center. The axis CC' rests upon a standard which is placed upon the whirling arm. A pencil, P, attached to the plane is pressed by a spring against a registering card at the side of the plane and perpendicular to it. The card contains a graduated arc whose center is at C and whose zero angle is under the pencil point at the vertical position of the plane. The distance of the trace from the center C registers the extension of the spring.

When the plane is at rest the extension of the spring measures the weight of the plane. When the plane is driven forward horizontally the pressure of the wind on the plane inclines it to an angle with the vertical, and the higher the speed the more it is inclined. For any position of equilibrium there is neither upward nor downward pressure on the guide-frame, and the whole resulting force acting on the plane, both that of gravity and that arising from the wind of advance, is borne by the spring.

The apparatus being mounted at the end of the arm of the large whirling table and being still, the weight of the plane is registered by an extension of the suspending spring corresponding to two pounds. Next, lateral motion being given (from the whirling table) and the plane being not only suspended but dragged forward, the spring is seen not to be extended further, but to *contract*, and to contract the more as the speed increases. The drawing contains a copy of the trace made by the pencil upon the recording sheet, showing how the spring contracts with the increasing angles of the plane with the vertical, where these angles correspond to increasing velocities of translation, or, we may almost say, to increasing speeds of flight. The experiment also calls attention to the fundamental circumstance that in the horizontal flight of an aeroplane increasing speeds are necessarily accompanied by diminishing angles of the plane with the horizontal.

The experiment may perhaps be held to be superfluous, since the principle involved, that the pressure of a fluid is always normal to a surface moving in it, is already well known; but we must distinguish between the principle and its application. Though when attention is called to it, the latter is seen to be so immediate a consequence of the principle as to appear almost self-evident, I must still call the application "unfamiliar" since, as will be seen, it indicates the way

to consequences which may appear almost paradoxical, such as that in horizontal frictionless flight, the greater the speed, the *less* the power required to maintain it. I do not mean that this illustration as here given, offers a satisfactory demonstration of this last consequence, but that any one who has really always possessed the idea that the experiment suggests, in its full import, must have been inclined to admit the possibility that machine flight grows more and more economical of power as higher speeds are attained—and this is not self-evident.

This preliminary apparatus can indeed, with little modification, be used to demonstrate this fact, but it is actually presented here, it will be noticed, not as demonstrative, but as illustrative, of the possibility suggested; a possibility whose fundamental importance justifies, and indeed demands, the fullest demonstration, which can be better supplied by apparatus designed to give data of precision for computing the actual work done in flight at different speeds; data which will be furnished here subsequently from quite other experiments.

CHAPTER IV.

THE RESULTANT PRESSURE RECORDER.

As preliminary to obtaining the data mentioned at the close of the last chapter, it is desirable to determine experimentally the direction of pressure of the air, (since the air is not an ideal fluid such as the theory contemplates,) on an inclined plane, and to investigate the assumption made by Newton that the pressure on the plane varies as the square of the sine of its inclination.

The second instrument constructed was, then, for the purpose of obtaining graphically, the direction of the total resultant pressure on an inclined plane (in practice a square plane) and roughly measuring its amount.* For this reason it will be called here the *Resultant Pressure Recorder*.

DESCRIPTION.

Plate V contains drawings of the instrument. Upon a base-board, BB', is a standard, E, carrying an arm, AA', hung symmetrically in gimbal joints. On the outer end of the arm a one-foot-square plane (called here the wind plane) is fastened with a clamp, and a graduated circle assists in setting the plane at different angles of inclination to the horizon. The extremity of the inner end of the arm carries a pencil, P, which registers on the surface of a vertical plane, which is in practice a sheet of diagram paper clamped on the surface FF' of an upright circular board fixed by a standard to the base-board BB'. The pencil-holder H fits closely into a ring at the center of a system of four equal radial springs attached to a circular frame, MM', projecting immediately in front of the registering board and concentric with it. This frame MM' is connected by supports to a close-fitting ring, which closes around the registering board and serves as a holder for the diagram sheets which are, as stated, clamped on the face FF' of the circular board. The radial-spring system and its frame may be rotated about the registering board, so that the diagram sheet may be rotated in its own plane. The inner or recording end of the arm is weighted so as exactly to counterpoise the outer end carrying the wind plane. Hence this plane is virtually *weightless*,

* Observations of the pressure on inclined planes have been made by previous experimenters, the first being by Hutton in the summer of 1738, just 100 years before those about to be recorded. But in the experiments of Hutton, as well as in most of the later ones, the horizontal component of the pressure on the inclined plane has been the subject of measurement, while the apparatus about to be described affords a measurement of the total normal pressure on the plane.

and when the apparatus is at rest the pencil-point rests in the center of the radial springs without pressure upon them, but when any force changes this position of equilibrium it is resisted and measured by the resultant extension of the four radial springs, shown by a definite departure of the pencil from the center in a definite direction.

The tension of these springs is determined before the apparatus is mounted for trial, by rotating the frame MM' about a longitudinal (imaginary) axis passing through the centers of the wind plane and registry plane. If the pencil end of the arm be weighted with (for instance) one pound, it traces out a curve on the paper corresponding to a one-pound tension in every direction. With two pounds another and larger curve is described, and so on till the resultant pressure of the four radial springs are then tabulated for every direction and every pressure which the wind of advance may later be expected to exercise. These curves are in practice very nearly circles.

The distance from the pencil to the gimbals is the same as that from the gimbals to the center of the wind plane, so that the wind pressure, considered as acting at the center of the plane, has the same lever arm as the pressure imposed by the extended springs. It should be particularly noted as a consequence of the above-described conditions that, although the wind plane is perfectly free to move in every direction, it is not free to rotate—*i. e.*, it is always during this motion parallel to itself.

The only other feature of the construction to be noted is the combination of a spring and an electro-magnet connected with the recording pencil. The pencil is held away from the paper by means of the spring until a desired velocity of rotation of the turn-table is attained, when by means of the electro-magnet the pencil is released and allowed to record.

The method of using the apparatus is as follows: The wind plane is set at an angle of elevation α ; a disk of paper is placed upon the recording board and oriented so that a line drawn through its center to serve as a reference line is exactly vertical. The whirling table is then set in motion, and when a uniform velocity has been attained a current is passed through the electro-magnet and the pencil records its position on the registering sheet. Since gravity is virtually inoperative on the counterpoised plane, the position of this trace is affected by wind pressure alone and is experimentally shown to be diametrically opposite to its direction, while the radial distance of the trace from the center is evidently a measure of the pressure on the plane. Thus the instrument shows at the same time the direction and magnitude of the resultant wind pressure on the plane for each inclination of the plane and for different velocities of the whirling table. Since the arms of the apparatus are exposed to the wind of rotation, the outer end, moving with greater velocity than the inner end, will be subject to a slightly

greater pressure. Preliminary experiments were therefore made without the wind plane for detecting this effect, with the result that no sensible difference was apparent between the pressure on the inner and outer arm, even at the highest speeds.

On August 25, 1888, the spiral springs were calibrated by hanging weights of 1, 2, and 3 pounds to the center of the springs and marking the displaced position of the center when the system was rotated through successive octants in the manner already described. Experimental circles were drawn through the system of points, and, the departures of the individual points being very small, the circles were adopted as the curves giving the relation between pencil excursions and pressures. From these curves the following table has been constructed :

TABLE I.

Excursion of trace.			Pressure.			Excursion of trace.			Pressure.			
<i>Centimeters.</i>			<i>Lbs.</i>	<i>Grammes.</i>	<i>Centimeters.</i>			<i>Lbs.</i>	<i>Grammes.</i>			
0.28	0.1	45			4.45	1.6	726					
0.55	0.2	91			4.73	1.7	771					
0.82	0.3	136			5.03	1.8	816					
1.10	0.4	181			5.33	1.9	862					
1.37	0.5	227			5.65	2.0	907					
1.64	0.6	272			5.98	2.1	953					
1.92	0.7	318			6.29	2.2	998					
2.20	0.8	363			6.60	2.3	1043					
2.47	0.9	408			6.91	2.4	1089					
2.73	1.0	454			7.25	2.5	1134					
3.02	1.1	499			7.60	2.6	1179					
3.30	1.2	545			7.93	2.7	1225					
3.59	1.3	590			8.28	2.8	1270					
3.89	1.4	635			8.63	2.9	1315					
4.17	1.5	680			9.00	3.0	1361					

After many days of preliminary experimentation, in which the instrument was gradually perfected by trial in successive forms before being brought to the condition to which the foregoing description applies, two days' experiments were made on August 27 and 28, and a final series on October 4, 1888. These are presented in detail in the accompanying tables, and consist of sixty-four separate experiments made with the plane set vertical and at angles varying between 5° and 45° with the horizon. The mean temperature is obtained from thermometer readings at the beginning and end of each set of experiments, which usually continued from one to two hours. The mean wind velocity is obtained from the readings of a Casella air meter. The apparatus is so placed upon the whirling arm that the center of the wind plane is nine meters from the axis of rotation. One registering sheet serves for a group of observations, consisting in

general of a succession of settings of the wind plane beginning with a setting at 90° and followed by diminishing angles of elevation. At each setting two observations are usually obtained by turning the register sheet through an angle of 180° . Thus the two traces made at the same setting should lie in a straight line passing through the center.

The method adopted in reading the traces is as follows: Straight lines are drawn through the center and the two traces made at each setting of the plane. The angle is then measured between the trace of the plane at 90° and the traces corresponding to other settings. The pressure being normal to the plane, these measured values should be the complement of the angles of elevation at which the plane is set. It will be seen by inspection of the accompanying tables that this relation approximately obtains.

Tables II, III, and IV contain all the original data of the experiments and their reduction. The first columns require no explanation. The fifth column (Tables II and III) gives the angle measured on the register-sheet between the radial direction of each trace and the direction of the trace made when the plane was set vertical. The sixth column gives the measured distance of the trace from the center, and the seventh gives the results of these extensions converted into pressure on the plane by means of Table I. The column headed $k_m = \frac{P}{V^2}$ contains the results of measurements of pressure on the normal plane expressed in terms of the coefficient k_m of the equation $P = k_m V^2$, in which V is the velocity of the plane in meters per second and P the pressure on the plane in grammes per square centimeter, the subscript m being used to designate units of the metric system.

Experiments with the Resultant Pressure Recorder to determine the resultant pressure, on a square plane moved through the air with different velocities and different inclinations.

TABLE II.—AUGUST 27, 1888.

S. P. LANGLEY, *Conducting experiments*; F. W. VERY, *Assisting*.

Wind plane, 1 foot square (929 square centimeters); center of wind plane, 9 m. from axis of rotation; barometer, 736 mm.; temperature at 6 p. m., 21°.0 C.; mean wind velocity, 0.52 meters per second.

Time of observation.	Angle of wind plane with horizon. <i>a</i>	Seconds in one revolution of turn-table.	Linear velocity of center of wind plane. <i>V</i> (meters per sec.).	Angle of trace with direction of trace made by plane set at 90°.	Departure of trace from center (centimeters).	Pressure on plane. <i>P_a</i> (grammes per sq. centimeter).	$k_m = \frac{P}{V^2}$	$P_{90} = .0077 V^2$	$\frac{P_a}{P_{90}}$
(p. m.)									
5:45	90°	12.65	4.47	1.10	0.195	0.0097		
	90	12.64	4.47	1.05	0.185	0.0092		
	30	12.58	4.49	57° 8	1.00	0.176	0.156	1.13
	15	12.67	4.46	75° 8	0.50	0.088	0.153	0.58
6:06	90	6.53	8.66	2.80	0.495	0.0066		
	90	6.60	8.57	2.80	0.495	0.0067		
	30	6.55	8.64	54° 5	2.60	0.463	0.575	0.80
	15	6.44	8.78	73° 5	1.65	0.293	0.594	0.49
	7.5	6.44	8.78	92° 0	0.80	0.141	0.594	0.24
	7.5	6.43	8.79	83° 0	0.80	0.141	0.595	0.24
6:29	90	5.74	9.85	4.10	0.722	0.0075		
	90	5.39	10.50	4.40	0.771	0.0070		
	30	4.87	11.61	60° 3	4.65	0.820	1.038	0.79

TABLE III.—AUGUST 28, 1888.

S. P. LANGLEY, *Conducting experiments*; F. W. VERY, *Assisting*.

Wind plane, 1 foot square (929 square centimeters); center of wind plane, 9 m. from axis of rotation; barometer, 736.6 mm.; temperature, 19°.4 C.; mean wind velocity, 0.37 meters per second.

Time of observation.	Angle of wind plane with horizon. α	Seconds in one revolution of turn-table.	Linear velocity of center of wind plane. V (meters per sec.).	Angle of trace with direction of trace made by plane set at 90°.	Departure of trace from center (centimeters).	Pressure on plane. P_a (grammes per sq. centimeter).	$k_m = \frac{P}{V^2}$	$P_{90} = .0077 V^2$	$\frac{P_a}{P_{90}}$	
(p. m.) 2:26	90°	12.62	4.48	1.03	0.180	0.0090			
	90	12.62	4.48	1.00	0.176	0.0088			
2:52	30	12.62	4.48	65°.8	0.70	0.122	0.155	0.79	
	15	12.57	4.50	78.8	0.65	0.112	0.156	0.72	
	90	6.45	8.77	3.25	0.576	0.0075			
	90	6.52	8.67	3.15	0.561	0.0075			
	45	6.48	8.73	48.5	3.30	0.585	0.587	1.00	
	45	6.51	8.69	46.0	3.10	0.551	0.581	0.95	
	30	6.45	8.77	61.5	3.00	0.532	0.592	0.90	
	30	6.45	8.77	60.5	3.20	0.566	0.592	0.96	
	15	6.43	8.79	75.6	2.05	0.366	0.595	0.61	
	15	6.40	8.84	76.5	1.90	0.341	0.602	0.57	
	7.5	6.44	8.78	86.0	1.45	0.259	0.594	0.44	
	7.5	6.45	8.77	80.5	1.15	0.205	0.592	0.35	
	3:40	90	5.05	11.20	5.40	0.930	0.0074		
		90	5.34	10.59	4.50	0.786	0.0070		
45		5.19	10.90	48.0	4.00	0.702	0.915	0.77	
45		5.29	10.69	48.0	4.10	0.722	0.880	0.82	
30		5.26	10.75	60.5	4.40	0.771	0.890	0.87	
30		5.44	10.40	59.0	3.90	0.683	0.833	0.82	
15		5.09	11.11	81.0	2.35	0.415	0.950	0.44	
15		5.18	10.92	75.5	2.20	0.387	0.918	0.42	
7.5		4.95	11.42	84.5	1.30	0.230	1.004	0.23	
7.5		5.33	10.61	85.5	1.45	0.259	0.867	0.30	
4:30		90	5.79	9.77	3.90	0.683	0.0072		
		90	5.78	9.78	3.85	0.673	0.0070		
		30	5.53	10.23	59.0	3.85	0.673	0.806	0.84
		30	5.56	10.17	58.8	3.60	0.634	0.796	0.80
	7.5	5.41	10.45	85.0	1.20	0.215	0.841	0.26	
	7.5	5.09	11.11	75.0	1.75	0.312	0.950	0.33	

REMARKS.—During these experiments the slight breeze has almost died away; angle of mean trace made by plane set at 90° with vertical plumb line drawn on register sheet = 95°.

TABLE IV.—OCTOBER 4, 1888.

F. W. VERY, *Conducting experiments*; JOSEPH LUDEWIG, *Assisting*.

Wind plane, 1 foot square (929 square centimeters); center of wind plane, 9 m. from axis of rotation; barometer, 732.3 mm.; temperature 10:15 a. m., 48° F.; 2:30 p. m., 56° F.; mean temperature, 52° F. = 11°.1 C.; mean wind velocity, 0.85 meters per second.

During these experiments both the velocity of the wind and its direction were quite variable.

Time of observation.	Angle of wind plane with horizon. <i>a</i>	Seconds in one revolution of turn-table.	Linear velocity of center of wind plane. <i>V</i> (meters per sec.).	Departure of trace from center (centimeters).	Pressure on plane. <i>P_a</i> (grammes per sq. centimeter).	$k_m = \frac{P}{V^2}$	$P_{\infty} = .0076 V^2$	$\frac{P_a}{P_{\infty}}$
(a. m.)								
11:40	15	12.50	4.52	0.5	0.088	0.155	0.57
	10	12.60	4.49	0.5	0.088	0.154	0.57
	10	12.50	4.52	0.5	0.088	0.155	0.57
(p. m.)								
1:07	20	12.50	4.52	0.7	0.122	0.155	0.79
	20	12.55	4.51	0.6	0.104	0.154	0.68
	90	6.60	8.57	3.0	0.532	0.0073	0.558	
	90	6.53	8.66	3.0	0.532	0.0071	0.570	
1:13	20	6.39	8.85	2.6	0.463	0.595	0.78
	20	6.43	8.79	2.3	0.408	0.587	0.70
	90	6.48	8.73	3.0	0.532	0.0070	0.579	
	90	6.45	8.77	3.0	0.532	0.0069	0.584	
1:30	10	6.43	8.79	1.3	0.233	0.587	0.40
	10	6.43	8.79	1.7	0.303	0.587	0.52
	90	6.50	8.70	3.0	0.532	0.0070	0.575	
	90	6.45	8.77	3.2	0.566	0.0074	0.584	
	15	6.47	8.74	1.5	0.268	0.581	0.46
	15	6.47	8.74	1.9	0.342	0.581	0.59
	90	6.45	8.77	3.8	0.664	0.0086	0.584	
	90	6.57	8.61	3.8	0.664	0.0090	0.563	
	5	6.43	8.79	1.0	0.176	0.587	0.30
1:52	5	6.45	8.77	1.1	0.195	0.584	0.33

Collecting the values of k_m from the several days' observations and reducing them to a common mean temperature of 10° C. and pressure of 735 mm., we have the following summary of results :

	k_m
August 27, 1888	0.00810
" 28, "	0.00794
October 4, "	0.00757

The observations of October 4 being of inferior accuracy to the others on account of the wind, which blew in sudden gusts, the mean of the first two days' experiments, viz., $k_m = 0.0080$, may be considered as the final value for the coefficient of normal pressure resulting from the experiments with this instrument.

The columns headed $P_{90} = 0.0077 V^2$ in the experiments of August 27 and 28, and $P_{90} = 0.0076 V^2$ in the experiments of October 4, give for each observation of the inclined plane the computed pressure which the plane would sustain if moving normally with its velocity V . The coefficient adopted for the computation is the mean value of k_m , resulting from the experiments of the day. The last column of the tables contains the ratio of the actual pressure on the inclined plane to the computed pressure on the normal plane given in the preceding column.

These ratios from the several days' experiments are collected in the following summary, and mean values are taken for the different angles of experiment. These mean ratios are plotted in Fig. 1, and a smooth curve is drawn to represent them.

TABLE V.—Summary of ratios of pressure on inclined plane to pressure on normal plane.

Linear velocity of plane (meters per sec.).	Angles of inclination.							Remarks.
	45°	30°	20°	15°	10°	7½°	5°	
4.5		1.13*	.79	.58	.57†	* Omit. † Give one-quarter weight.
				.57	
8.7	1.00	0.79	.68	.72	.57†			
	0.95	0.80	.78	.49	.40	.24	.30	
		0.90	.70	.62	.52	.24	.33	
11.2		0.955744		
				.4635		
				.59				
	0.77	0.794423		
	0.82	0.874230		
	0.8226			
	0.8433			
	0.80							
Mean	0.89	0.84	.74	.55	.48	.30	.31	

FIG. 1.

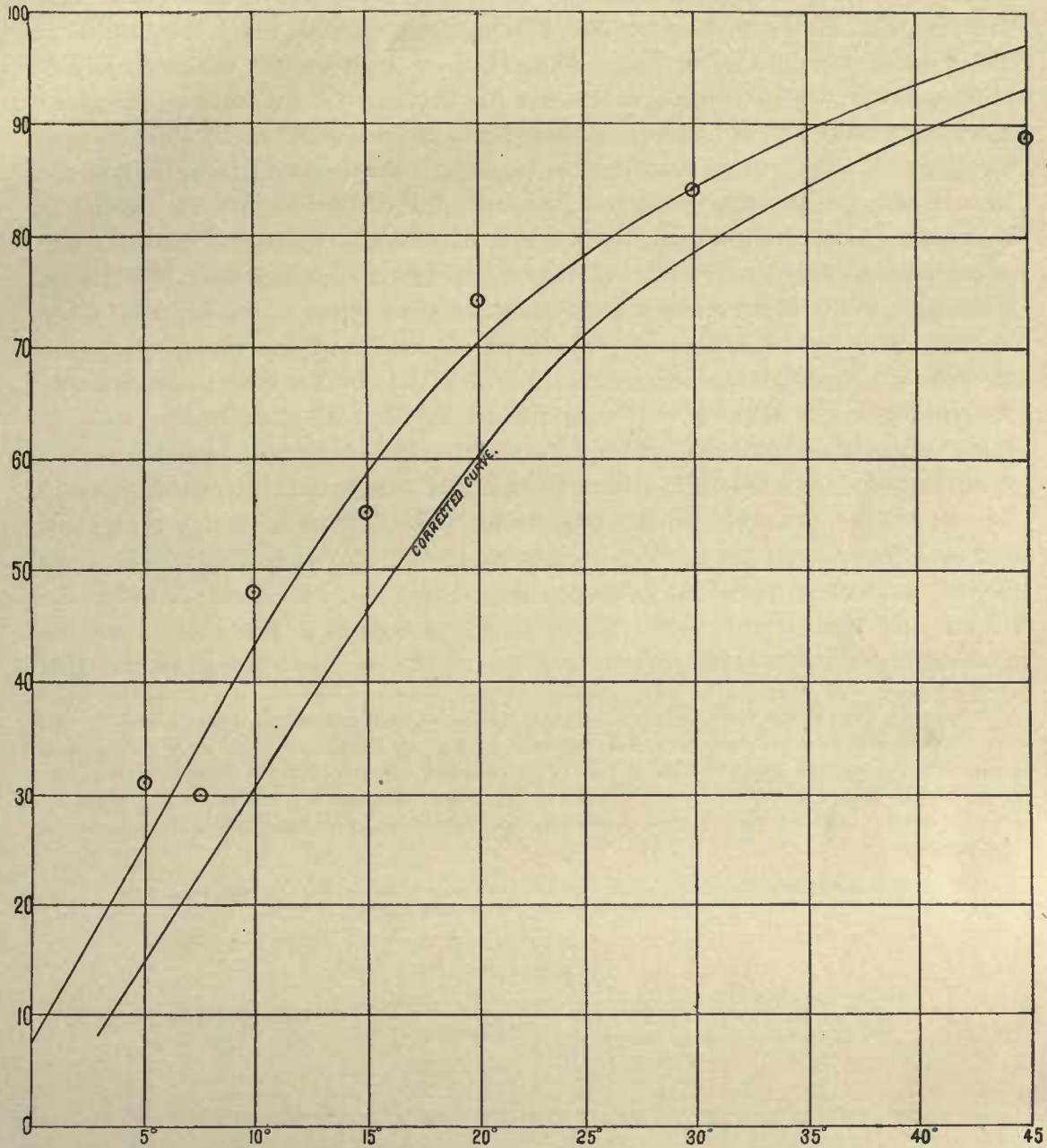

Ratio of the total normal pressure (P_a) on an inclined square plane to the pressure (P_{90}) on a normal plane, the planes moving in the air with the same velocity.

Abscissæ. Angles of inclination (α) of plane to horizon.

Ordinates. $\frac{P_a}{P_{90}} = F(\alpha)$ (expressed as a percentage).

⊙ Represents the mean of observed points for each angle of experiment.

The values in the tables are subject to a correction resulting from a flexure in the balance-arm and its support. It was observed (see note in Table III) that the trace of the plane set at 90° did not coincide with the horizontal (*i. e.*, the perpendicular to the vertical) line marked on the trace, but was uniformly 4° or 5° below it; so that the angle between the vertical and the trace of the plane did not measure 90° , as had been assumed, but uniformly 94° or 95° , the average being $94^\circ.6$. This result was found to be due to the bending backward of the balance-arm and its support by the pressure of the wind, while the recording board and plumb-line presented only a thin edge to the wind, and consequently remained relatively fixed. During motion, therefore, the plane actually had an inclination to the horizon about 5° greater than the angle at which it was set when at rest. This flexure seemed to obtain for all angles of experiment, but with indications of a slightly diminishing effect for the smaller ones; consequently the pressure ratios above given for angles of 45° , 30° , 20° , etc., really apply to angles of about 50° , 35° , 25° , etc. After making this correction the final result of the experiments is embodied in the line of Fig. 1 designated "corrected curve."*

At the inception of the experiments with this apparatus it was recognized that the Newtonian law,† which made the pressure of a moving fluid on an inclined surface proportional to the square of the sine of the angle between the surface and the current, is widely erroneous, though it is still met in articles relating to fluid pressures, and vitiates the results of many investigations that

* The ratios given by the "corrected curve" of the diagram have been tabulated for angles of every 5° and then compared with all the experiments and formulæ with which I am acquainted. Only since making these experiments my attention has been called to a close agreement of my curve with the formula of Duchemin, whose valuable memoir published by the French War Department, *Mémoires de l'Artillerie* No. V, I regret not knowing earlier. The following table presents my values, the values given by Duchemin's formula, and a column of differences:

Ratio of the total pressure (P_a) on an inclined square plane to the pressure (P_{90}) on a normal plane moved in the air with the same velocity.

Angles of inclination of plane to direc- tion of motion. <i>a</i> .	$\frac{P_a}{P_{90}}$ as given by—		Difference: Duche- min—Langley.
	Experiments with Resultant Pres- sure Recorder.	Duchemin's formula: $\frac{2 \sin a}{1 + \sin^2 a}$	
5°	.15	.17	+ .02
10	.30	.34	.04
15	.46	.48	.02
20	.60	.61	.01
25	.71	.72	.01
30	.78	.80	.02
35	.84	.86	.02
40	.89	.91	.02
45	.93	.94	.01

† Implicitly contained in the Principia, Prop. XXXIV, Book II.

would otherwise be valuable. Occasional experiments have been made since the time of Newton to ascertain the ratio of the pressure upon a plane inclined at various angles to that upon a normal plane, but the published results exhibit extremely wide discordance, and a series of experiments upon this problem seemed, therefore, to be necessary before taking up some newer lines of inquiry.

The apparatus with which the present experiments were made, was designed to give approximations to the quantitative pressures, rather than as an instrument of precision, and its results are not expected to afford a very accurate determination of the law according to which the pressure varies with the angle of inclination of the surface to the current, but incidentally the experiments furnish data for discriminating between the conflicting figures and formulæ that now comprise the literature of the subject. We may remark that they incidentally show that the effect of the air friction is wholly insensible in such experiments as these; but the principal deduction from them is that the sustaining pressure of the air on a plane 1 foot square, moving at a small angle of inclination to a horizontal path, is many times greater than would result from the formula implicitly given by Newton. Thus for an angle of 5° this theoretical vertical pressure would be $\sin^2 5^\circ \cos 5^\circ = 0.0076$ of the pressure on a normal plane moving with the same velocity, while according to these experiments it is in reality 0.15 of that pressure, or *twenty times* as great as the theoretical amount

CHAPTER V.

THE PLANE-DROPPER.

It is so natural to suppose that to a body falling in the air under the influence of gravity, it is indifferent whether a lateral motion is impressed upon it or not, as regards the time of its fall, that we may sometimes find in elementary text-books the statement that if a ball be shot from a cannon horizontally, at any given height above the ground, and if a ball be dropped vertically at the same instant with the discharge, the two projectiles will reach the ground at the same time, and like illustrations of a supposed fact which has in reality no justification in experience. According to the experiments I am about to describe, this cannot be the case, although it requires another form of projectile to make the difference in the time of fall obvious.

It is shown by the following experiments that if a thin material plane be projected in its own plane horizontally, it will have a most conspicuously different time of falling according to the velocity of its lateral translation; and this time may be so great that it will appear to settle slowly down through the air, as it might do if almost deprived of weight, or as if the air were a highly viscous medium, the time of fall being (it will be observed) thus prolonged, when there is no inclination of the plane to the horizon—a noteworthy and unfamiliar fact,* which is stated here on the ground of demonstrative experiment. The experimental quantitative demonstration of this important fact, is the primary object of the instrument I am about to describe, used with the horizontal plane. It is, of course, an entirely familiar observation that we can support an inclined plane by moving it laterally, deriving our support in this case from the upward com-

* An analogous phenomenon concerning the movement of one solid over another yielding one, such as when
"Swift Camilla scours the plain,

"Flies o'er the unbending corn, and skims along the main;"

or in the familiar illustration of the skater on thin ice, or in the behavior of missiles like the boomerang, has long been observed; and yet, remarkable as its consequences may be, these seem to have attracted but little attention. Neither has the analogy which it is at least possible may exist between this familiar action of the skater upon the ice and of the potential flying-machine in the air been generally observed till lately, if at all—at least, so far as I know, the first person who has seemed to observe the pregnant importance of the illustration is Mr. Wenham, whom I have already alluded to. I do not, then, present the statement in the text as a fact in itself unpredictable from experience, for it is a familiar fact that the air, like every material body, must possess inertia in some degree. It is the quantitative demonstration of the extraordinary result of this inertia which can be obtained with simple means in causing the thin air to support objects a thousand times denser than itself, which I understand to be at the time I write, both unfamiliar in itself, and novel in its here shown consequences.

ponent of pressure derived from the wind of advance; but, so far as I am now aware, this problem of the velocity of fall of a horizontal plane moving horizontally in the air has never been worked out theoretically or determined experimentally, and I believe that the experimental investigation whose results I am now to present is new.

With all the considerations above noted in view, I have devised a piece of apparatus which, for distinction, I will here call the *Plane-Dropper*, intended, in the first place, to show that a horizontal plane in lateral motion requires an increased time for its descent; second, to make actual measurement of the time of fall of variously shaped planes and to give at least the first approach to the procuring of the quantitative data; third, to connect these experiments with those immediately allied to them, where the plane has an inclination to the horizon; and, fourth, to make experiments to show the depth of the air strata disturbed by the moving plane during the time of its passage.

Drawings of the *Plane-Dropper* are given in plate VI. F is a vertical iron frame with a wooden back WW, which is shown fastened by bolts B to the end of the arm of the turn-table. The fourth side of the rectangle is a planed brass frame on which an aluminum falling-piece runs up and down on friction rollers. The plate contains enlarged front and side views of the falling-piece, and a section of the brass frame and falling-piece, showing the arrangement of the ebonite friction rollers. By means of the clamps CC' the falling-piece carries two wooden planes, which may be set by the clamps DD' horizontal, or at any angle with the horizon up to 45°. Guy lines extend from the top and bottom of the falling-piece to the outer edges of the planes and keep them from bending. A detent at the top of the frame holds the falling-piece until released at any desired instant by the action of an electro-magnet, M. A spring cushion, S, at the bottom of the frame, breaks the force of the fall.

Provision is made for setting the brass frame vertical, and by means of the handle H the frame can be revolved 180° about its vertical axis, so as to present successively one side or the other side to the wind of advance, and thus to eliminate any defect in setting the wings absolutely horizontal, or any inequality in the instrument not otherwise suspected.

The total fall is four feet, and the total time of fall is registered electrically by means of contact-pieces *a* and *e*, near the top and bottom of the frame. As soon as released, the aluminum falling-piece presses the contact-piece *a* against the frame and completes the circuit. While falling, the circuit is open, and at the distance of four feet the contact-piece *e* is pressed against the frame and the circuit is again closed. In November, 1890, three additional contact-pieces, *b*, *c*, *d*, were added, so as to measure the time of fall through each successive foot. The registration is made on the stationary chronograph, together with that of

the quadrant contacts of the turn-table, the currents for the moment being cut off from the quadrant contacts and sent through the *Plane-Dropper*.

The dimensions and weight of the principal parts of the apparatus are as follows :

Length of brass tube.....	160 centimeters.
Length of aluminum falling-piece.....	25 "
Length of buffers.....	5 "
Actual distance of fall (between contacts).....	122 "
Distance of center of brass frame and falling-piece from center of turn-table, when mounted.....	981 "
Weight of falling-piece.....	350 grammes.

The planes are made of varnished pine about 2½mm. thick, and stiffened on one edge with an aluminum strip.

Five different pairs were used, having the following dimensions and weights :

(1) Two planes, each *6 x 12 in. (15.2 x 30.5 cm.); weight of pair, 123 grammes.	
(2) " " " 8 x 9 in. (22.9 x 20.3 cm.); " " 115 "	
(3) " " " 12 x 6 in. (30.5 x 15.2 cm.); " " 114 "	
(4) " " " 18 x 4 in. (45.7 x 10.2 cm.); " " 114 "	
(5) " " " 15 x 4 in. (38.1 x 10.2 cm.); " " 118 "	

Each pair of planes, therefore, except the last, has an area of one square foot, and weighs, with the aluminum falling-piece, approximately one pound.

It may be desirable to add that this instrument was constructed with special pains in all the circumstances of its mechanical execution, the very light falling-piece, for instance, moving on its friction wheels so readily that it was not possible to hold the rod in the hands sufficiently horizontal to keep the "falling-piece" from moving to one end or the other, like the bubble of a level held in the same manner.

Preliminary experiments were made to determine the effects of friction on the time of fall, when the *Plane-Dropper* is in rapid horizontal motion, by dropping the aluminum falling-piece without planes attached, and it was found that under these circumstances the time of fall is not sensibly greater when in rapid motion than when at rest. As a further test, the planes were then attached to the falling-piece in a vertical position, that is, so as to present their entire surface to the wind of rotation, and thus to produce a friction very much greater than any occurring in the subsequent experiments; but the time of fall was not increased to any notable degree. The effect of friction and other instrumental errors are shown thus, and by considerations already presented, to be negligible in comparison with the irregularities inevitably introduced by irregular air currents

* First measurement refers to advancing edge.

when the whirling table is in motion, which appear in the observations. The probable error of the measured time of falling in still air, when only instrumental errors are present, is within $\frac{1}{100}$ of a second.

The first series of experiments with horizontal planes was made May 25 and June 10 to June 14, 1889, and was devoted to the first two objects already set forth, namely:

1st. To show by the increased time of fall that the supporting power of the air increases with the horizontal velocity of the body; and,

2d. To get first approximations to the times of falling of rectangular planes of different shapes and aspects, the latter condition having reference to whether the long or the short side of the rectangle is perpendicular to the direction of advance.

An abstract of the note book for June 11, 1889, is given here as an example of the detailed records made in these experiments.

JUNE 11, 1889.—S. P. LANGLEY, *Conducting experiments and recording*; F. W. VERY, *Assisting*.

Notes: "A" and "B" designate the direct and reversed positions of the brass frame and falling piece; belt on third pulley.

To determine time of falling.

Size and attitude of planes.	Time of 1 revolution of turn-table (seconds).	Time of falling (seconds).
18 x 4-inch planes, horizontal.	3.8 3.8 3.75 4.25	A 1.30 A 1.15 B 1.20 B 1.15
12 x 6-inch planes, horizontal:		
At rest (in open air).		0.52
" " "		0.52
" " "		0.52
" " "		0.54
In motion on turn-table	6.0	B 0.71
" " "	6.2	B 0.80
" " "	6.1	A 0.76
" " "	6.1	A 0.80
" " "	3.5	A 1.00

The detailed observations with the five different planes already described are contained in Tables VI and VII, and the results are presented graphically in figure 2, where the times of fall are plotted as ordinates, and abscissæ are horizontal velocities of translation.

TABLE VI—MAY 25, 1889.

To find the time of fall of different planes; plane-dropper stationa; y.

S. P. LANGLEY, Conducting experiments; F. W. VERY, Assisting.

Barometer, 731.5 mm.; temperature, 17°.5 C.; wind, light.

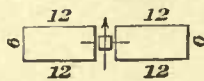
Size of planes.	Weight (with dropping piece).		Angle with horizon.	Time of fall of 4 feet (1.22 meters). (Seconds.)
	(Grammes.)	(Pounds.)		
One pair 12 x 6 inches (30.5 x 15.2 cm.). 	464	1.02	0°	0.58
			0	0.58
			0	0.52
			45	0.54
			45	0.55
One pair 18 x 4 inches (45.7 x 10.2 cm.).	464	1.02	0	0.54
			0	0.55
			45	0.55

Result: The time of fall of both planes, at angles both of 0° and 45°, is, approximately, 0.55 seconds.

TABLE VII—JUNE 10, 11, 12, AND 14, 1889.

S. P. LANGLEY, Conducting experiments; F. W. VERY, Assisting.

Mean barometer, 734.0 mm.; mean temperature, June 10, 26.6° C.; June 11, 17.8° C.; June 12, 21.1° C.; June 14, 26.1° C.

To determine the times of fall of horizontal planes endowed with horizontal velocity.					To determine the horizontal velocities at which inclined planes are supported by the air.				
Dimensions and aspect of plane.	Date.	Time of one revolution of turntable (seconds).	Horizontal velocity (meters per second).	Time of fall (seconds).	Date.	Angle of elevation.	Time of one revolution of turntable (seconds).	Horizontal velocity (meters per second).	
 18 x 4 inches (45.7 x 10.2 cm.). Weight, 1.02 lbs. (464 grammes). Radius of rotation to center of planes, 9.81 m.	1889. June 10	0.00	0.0	0.53	1889. June 10	16°	5.1	12.1	
	"	5.70	10.8	0.70	"	5	3.4	18.1	
	"	5.90	10.4	0.65					
	"	3.35	18.4	1.62					
	"	3.45	17.9	1.65					
	"	5.80	10.6	0.85					
	"	4.35	14.2	0.90					
	"	3.75	16.4	1.08					
	"	June 11	3.80	16.2	1.30	June 11	20°	6.0	10.3
	"	"	3.80	16.2	1.15	"	15	6.2	9.9

TABLE VII—Continued.





Dimensions and aspect of plane.	Date.	Time of one revolution of turntable (seconds).	Horizontal velocity (meters per second).	Time of fall (seconds).	Date.	Angle of elevation.	Time of one revolution of turntable (seconds).	Horizontal velocity (meters per second).
 <p>18 x 4 inches (45.7 x 10.2 cm.). Weight, 1.02 lbs. (464 grammes).</p>	1889. June 11	3.75	16.4	1.20	1889. June 11	31°	3.3	18.7
	"	4.25	14.5	1.15	"	"	"	"
	"	3.00	20.5	1.95	June 12	3	3.35	18.4
	"	3.60	17.1	1.50	"	2	2.85	21.6
	"	3.00	20.5	2.55	"	"	"	"
	"	3.05	20.2	2.68	"	"	"	"
	"	3.10	19.9	2.75	"	"	"	"
	"	3.15	19.6	2.05	"	"	"	"
	"	3.70	16.8	1.65	"	"	"	"
	 <p>12 x 6 inches (30.5 x 15.2 cm.) Weight, 464 grammes.</p>	"	0.00	0.0	0.56	June 11	25°	5.6
"		6.15	10.0	0.80	"	6	3.8	16.2
"		6.05	10.2	0.74	June 12	5	3.3	18.7
June 11		3.50	17.6	1.00	"	"	"	"
"		3.40	18.1	1.16	"	"	"	"
June 12		2.87	21.4	1.29	"	"	"	"
"		2.82	21.9	1.59	"	"	"	"
 <p>Weight, 465 grammes.</p>	"	0.0	0.57	"	25°	6.0	10.3
	"	13.15	4.7	0.62	"	15	4.9	12.6
	"	3.50	17.6	0.72	"	12	4.2	14.7
	"	2.85	21.6	0.82	"	6	2.9	21.2
	"	2.65	23.3	0.86	"	"	"	"
	"	0.0	0.57	"	"	"	"
 <p>6 x 12 inches. Weight, 473 grammes.</p>	"	0.0	0.57	"	30°	5.9	10.5
	"	11.65	5.3	0.58	"	20	5.0	12.3
	"	4.10	15.0	0.65	"	15	4.2	14.7
	"	5.10	12.1	0.70	"	13	3.8	16.2
	"	2.78	22.2	0.72	"	9	2.9	21.2
 <p>15 x 4 inches (38.1 x 10.2 cm.). Weight, 468 grammes.</p>	June 14	5.65	10.9	0.76	June 14	20°	5.25	11.7
	"	3.10	19.9	1.28	"	15	5.10	12.1
	"	3.00	20.5	1.28	"	15	4.65	13.3
	"	"	"	"	"	10	4.55	13.6
	"	"	"	"	"	7	3.85	16.0
	"	"	"	"	"	5	3.30	18.7
"	"	"	"	"	4	3.10	19.9	

FIG. 2.

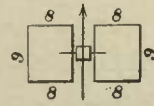
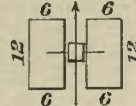

Times of falling 4 feet of horizontal planes on the *Plane-Dropper*.
 Average weight of planes = 465 grammes.
 Abscissæ : = Horizontal velocities of translation in meters per second.
 Ordinates : = Times of fall in seconds.

Perhaps the most important primary fact exhibited by these experiments is that the time of fall for horizontal planes of all shapes is greater as the horizontal velocity increases, and also (as the form of the curves shows) that this retardation in the velocity of falling goes on at an increasing rate with increasing velocities of translation.

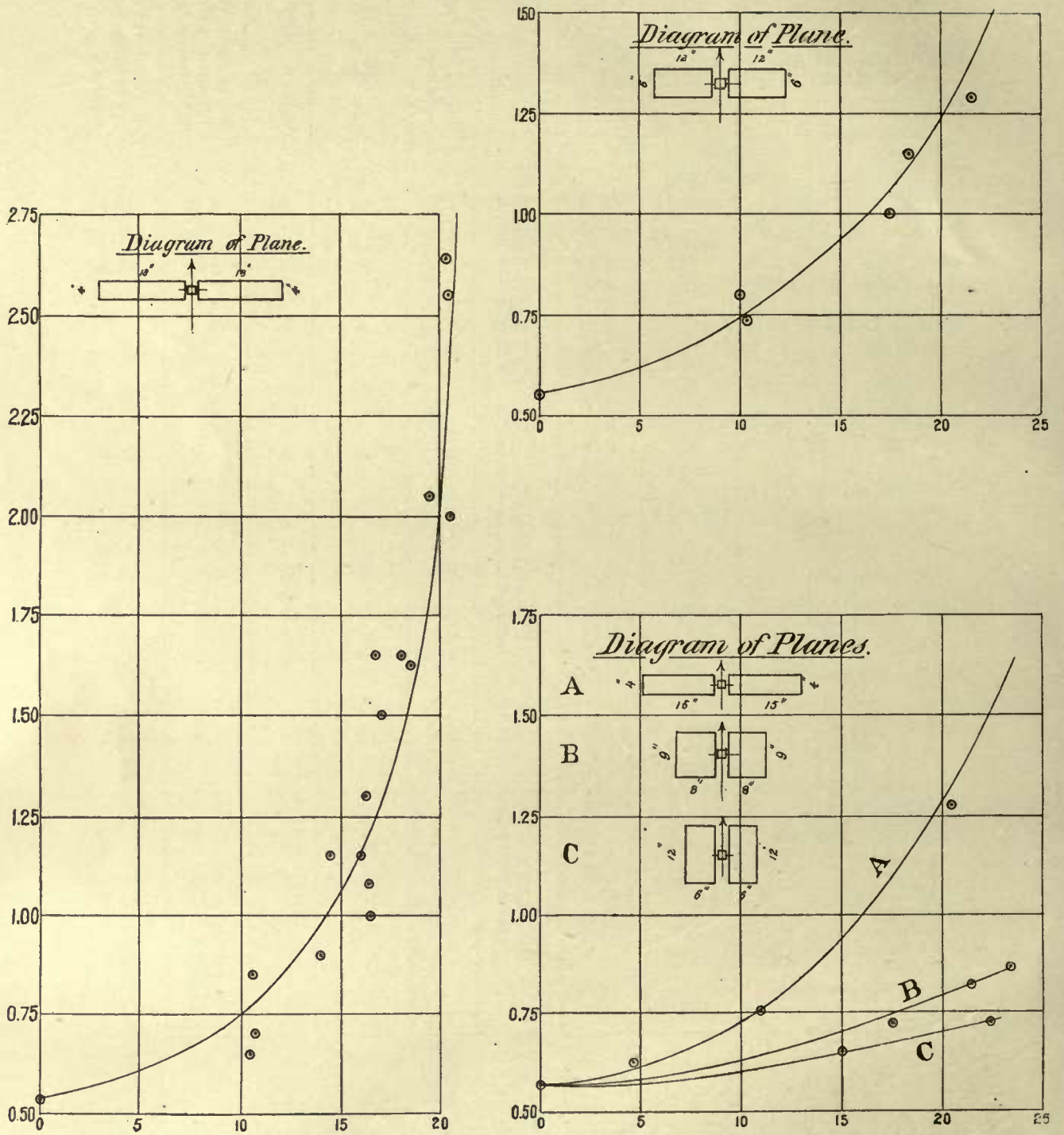
Secondly, we see that those planes whose width from front to back is small in comparison with the length of the advancing edge have a greater time of fall than others. This difference is uniform and progressive from the 6 x 12 inch planes to the 18 x 4 inch planes. Expressing this advantage quantitatively, the curves show that the planes having an advancing edge of 6 inches and a width of 12 inches from front to back, when they have a horizontal velocity of 20 meters per second, fall the distance of 4 feet in 0.7 second, while planes of the same area and weight having the advancing edge 18 inches and 4 inches from front to back, when moving with the same velocity, are upheld to such an extent that their time of fall is 2 seconds. This interesting comparative result is also indirectly valuable in giving additional evidence that the largely increased time of fall of the better-shaped planes at the high speeds is not due to the lateral friction of the falling-piece against the frame. The friction with the 6 x 12 inch planes is as great as with any of the others, yet their time of falling is only slightly greater at high speeds than at rest. Attention is called to the fact that at the highest velocity attained in the present series of experiments, 20 meters per second, the curve shows that the time of falling of the 18 x 4 inch planes was increasing very rapidly, so much so as to make it a subject of regret that the slipping of belts prevented experiments at still higher speeds. We may, however, reasonably infer that with a sufficient horizontal velocity, the time of fall may be prolonged to any assigned extent, and that for an infinite velocity of translation, the time of fall will be infinite, or, in other words, that the air will act as a solid support.

It may be of interest to connect these observations with some partly analogous facts which are more familiar.

It is frequently observed that a sheet of very thin ice will bear up a skater if he is in rapid motion which would not sustain his weight if he were still; and even if we neglect the slight difference of specific gravity between water and ice, and suppose the latter to have no differential buoyancy, the rapid skater will still be able to pass safely over ice that would not bear his weight if he were at rest; for while his mass is the same in both cases, that of the ice called into play in sustaining him is only that corresponding to one unit of area when he is at rest, but to many when he is moving.

In this form of explanation and illustration the attention is directed only to the action of the air *beneath* the plane, but in fact the behavior of the air *above*

the plane is of perhaps equal importance, and its action has been present to my mind throughout these experiments, although for the purpose of concise exposition only the former is here referred to. By analogous reasoning in the case of a heavy body immersed in any continuous fluid, even gaseous, while the mass of air or gas whose inertia is called into action is small and affords a slight sustaining power when the body is at rest, it becomes greatly multiplied with lateral motion, and the more rapid this lateral motion, the greater will be the sustaining action of the fluid. So, then, in the case of any heavy body which will fall rapidly in the air if it fall from rest, the velocity of fall will be more and more slow if the body be given successively increasing velocities of lateral translation and caused to run (so to speak) upon fresh masses of air, resting but a moment upon each.

The above analogy, in spite of its insufficiency as regards the effect of elasticity, is useful, and may be further extended to illustrate the relative results obtained with the differently shaped planes and with the same plane under different "aspects;" thus the action on the air of a plane whose advancing edge is twice its lateral edge—*e. g.*, the 12 x 6 inch plane, with 12-inch side foremost—may be compared to that of two skaters side by side, each advancing over his own lines of undisturbed ice; but the same plane with the 6-inch side foremost, to the same skaters, when one is behind the other, so that the second is passing over ice which has already yielded to the first and is partly sinking.

The second series of experiments, made on the same dates as the first, was to cover the third object of experiment—that is, to determine for different angles of inclination what speed is necessary in order to derive an upward thrust just sufficient for sustaining the planes.

The results of these two series of experiments furnish all that is needed to completely elucidate the proposition that I first illustrated by the suspended plane, namely, that the effort required to support a bird or flying machine in the air is greatest when it is at rest relatively to the air, and diminishes with the horizontal speed which it attains, and to demonstrate and illustrate the truth of the important statement that in actual horizontal flight it costs absolutely less power to maintain a high velocity than a low one. It has already been explained that when the planes have such an angle of elevation and such a horizontal velocity that they first rise from their support and are then with a slightly diminished velocity just sustained without falling, they are said to "soar," and the corresponding horizontal velocity is called "soaring speed." Attention has already been called to the importance thus attachable to the word "horizontal" as qualifying flight, and implying its most economic conditions, when no useless work is expended.

The actual mode of experiment with the inclined planes was to set the plane at a given angle of elevation, for example 5°, and approximate to the critical soaring speed by gradual variations of velocity, both above and below it. The following extract from the note book shows the character of the record made in executing this experiment :

12 x 6 inch planes, inclined.

Angle of inclination.	Time of 1 revolution of turn-table (seconds).	Attitude of plane.
25°	5.6	Soaring.
6	3.8	"

18 x 4 inch planes, inclined.

Angle of inclination.	Time of 1 revolution of turn-table (seconds).	Attitude of plane.	Estimated result.
4°	3.4	More than soaring	{ For angle 3½°, soaring speed = 1 revolution in 3.3 seconds.
3	3.2	Not quite soaring	
20	6.0	Soaring.	{ For angle 15°, soaring speed = 1 revolution in 6.2 seconds.
15	5.5	More than soaring	
15	6.8	Not quite soaring	

The detailed observations have already been given in Tables VI and VII and the results are plotted in Figure 3, in which the ordinates are soaring speeds and the abscissæ are the corresponding angles of inclination of the planes to the horizon. This diagram shows that when set at an angle of 9° the 6 x 12 inch plane requires a horizontal velocity of 21.2 meters per second to sustain it in the air, while the 18 x 4 inch plane, set at the same angles, is supported by the air when it is driven at a velocity of only 14 meters per second. The work to be done in maintaining the flight at 14 meters per second is less than one-half that for 21.2 meters per second, the angle remaining the same.

These experiments enable us to make a first computation of the work expended in horizontal flight. Let us, then, determine the horse-power required to drive the two 18 x 4 inch planes horizontally in the air, when the planes are inclined successively at 9° and at 5°. The work done per second is given by the product $R \times V$, R being the horizontal component of pressure on the plane, and V the

FIG. 3.

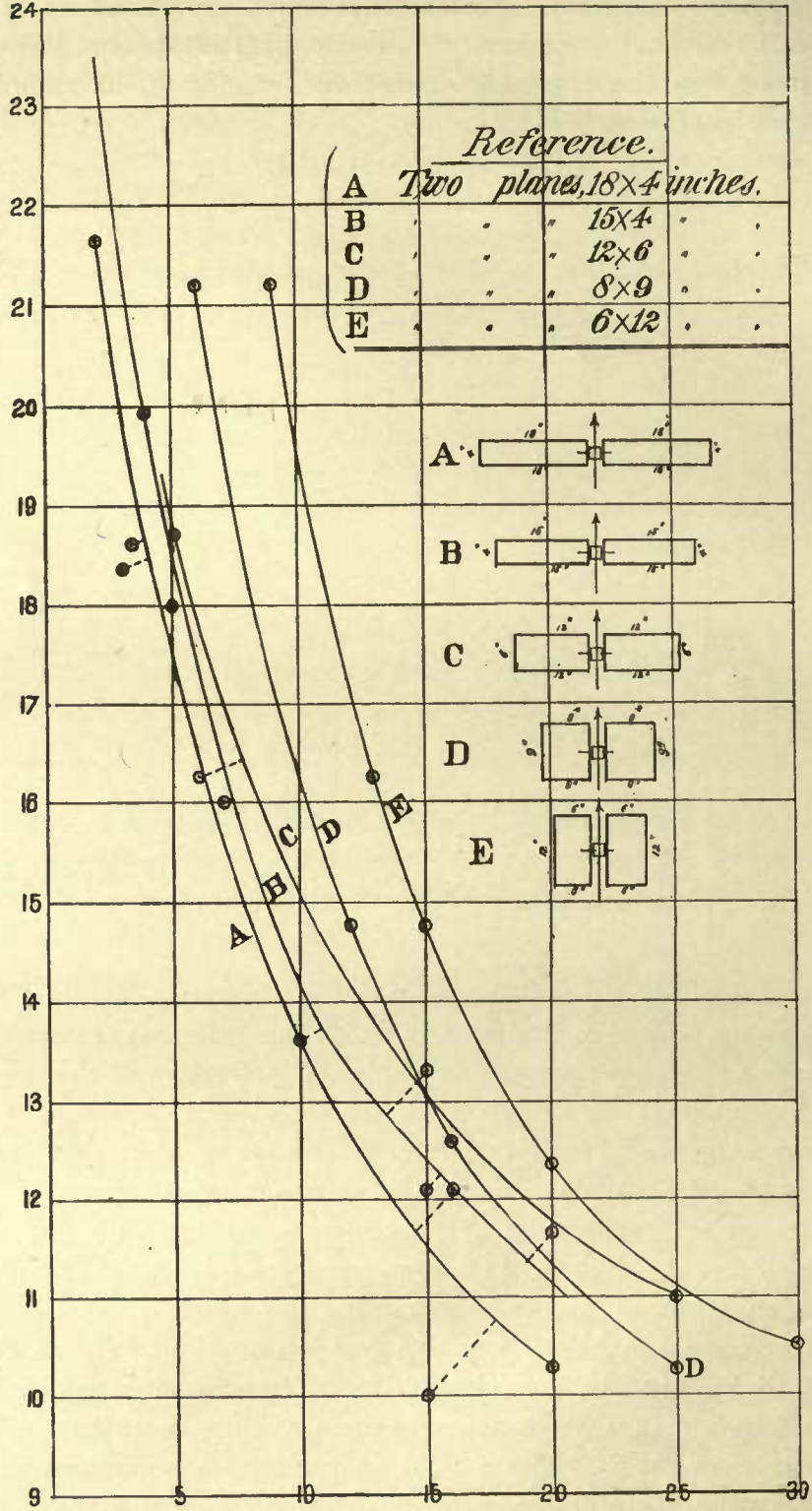

Velocities of soaring of inclined planes on the *Planc-Dropper*.
 Average weight of plane = 465 grammes.
 Abscissæ: = Angles of inclination (α) of plane to horizon.
 Ordinates: = Velocities in meters per second.

soaring speed. From Fig. 3 we find that the soaring velocities corresponding to these angles are respectively 14 and 17.2 meters per second.

Taking the vertical component of pressure as equal to the weight of the plane, 464 grammes, which relation obtains at soaring speed, the horizontal component of pressure, or the resistance to advance, is given by the formula :

$$R = 464 \tan 9^\circ = 73.3 \text{ grammes, for } 9^\circ;$$

$$R = 464 \tan 5^\circ = 40.6 \text{ grammes, for } 5^\circ,$$

a formula which is immediately derived from the fundamental principles of mechanics and appears to involve no assumption whatever. The work done per minute, $R \times V$, is 62 kilogrammeters (450 foot-pounds) for 9° , and 43 kilogrammeters (312 foot-pounds) for 5° . For the former case this is 0.0156 horse-power, and for the latter case, approximately 0.0095 horse-power ; that is, less power is

FIG. 4.

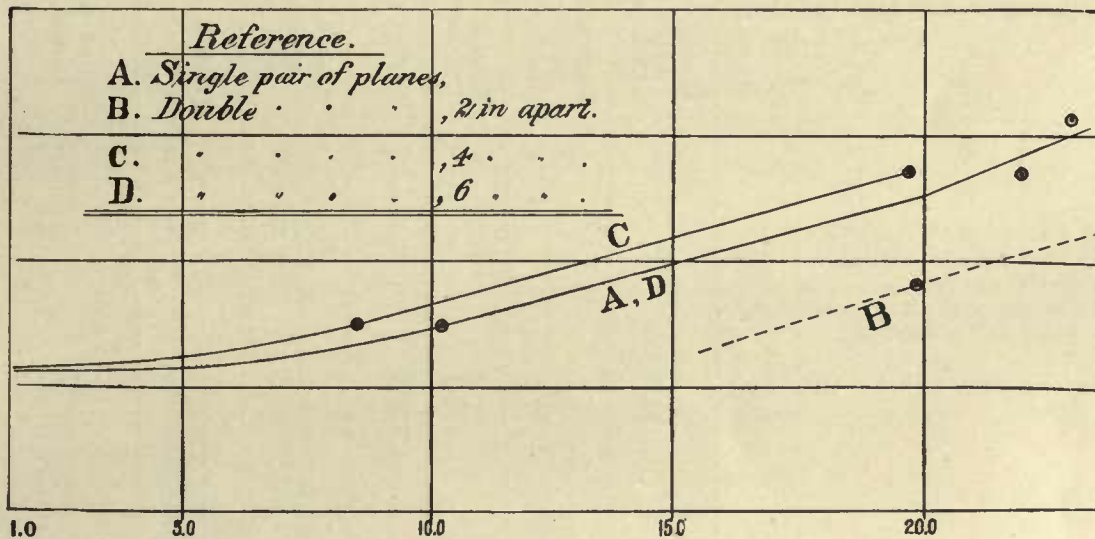

Times of falling 4 feet of single and double pairs of 15 x 4 inch planes.
 Abscissæ: Horizontal velocities of translation in meters per second.
 Ordinates: Time of fall in seconds.

required to maintain a horizontal velocity of 17 meters per second than of 14; a conclusion which is in accordance with all the other observations and the general fact deducible from them, that it costs less power in this case to maintain a high speed than a low one—a conclusion, it need hardly be said, of the very highest importance, and which will receive later independent confirmation.

Of subordinate, but still of very great, interest is the fact that if a larger plane have the supporting properties of this model, or if we use a system of planes like the model, less than one-horse power is required both to support in the air a plane or system of planes weighing 100 pounds, and at the same time to propel it horizontally at a velocity of nearly 40 miles an hour.

The third series of experiments made with the plane-dropper is designed to investigate the effect of two sets of planes, one above the other. For this purpose the planes and falling piece are so weighted that the previous ratio of weight to surface is retained; that is, in the previous case the weight is 1 pound to 1 square foot of surface, and with the double set of planes the weight is

Experiments with two sets of planes, one above the other.

TABLE VIII.—JUNE 14, 1889.

Dimensions and aspect of plane.	To determine the times of fall of a system of horizontal planes endowed with horizontal velocity.			To determine the horizontal velocities at which a system of inclined planes will be supported by the air.			
	Time of one revolution of turntable (seconds).	Horizontal velocity (meters per second).	Time of fall (seconds).	Angle of elevation α .	Time of one revolution of turntable (seconds).	Horizontal velocity.	
						(Meters per second.)	(Feet per second.)
 <p>15 x 4 inches (38.1 x 10.2 cm.). Double pair of planes, 2 inches (5.1 cm.) apart. Total weight of planes and falling-piece, 942 grammes.</p>	3.1	19.9	0.90	10°	4.33	14.2	46.7
				8	3.85	16.0	52.5
				6	3.48	17.7	58.1
				6	3.35	18.4	60.3
				5	Did not rise.		
<p>Same planes, 4 inches (10.2 cm.) apart.</p>	7.30	8.4	0.73	15	5.30	11.6	38.1
	3.13	19.7	1.36	10	4.65	13.3	43.5
				10	4.65	13.3	43.5
				7	3.38	18.2	59.8
				5	3.33	18.5	60.7
				4	3.33	18.5	60.7
				4	3.27	18.9	61.8
<p>Same planes, 6 inches (15.2 cm.) apart.</p>	5.88	10.5	0.73	20(?)	5.60	11.0	36.1
	2.78	22.2	1.34	15	5.40	11.4	37.4
	0.00	0.0	0.55	10	4.55	13.5	44.4
	2.65	23.3	1.60	7	3.95	15.6	51.2
				5	3.45	17.9	58.6
				5	3.45	17.9	58.6
				4	2.93	21.0	69.0
			4	2.95	20.9	68.5	
			2½	2.85	21.6	71.0	

made 2 pounds to 2 square feet. The preceding experiments, made with the single pair of 15 x 4 inch planes, were then repeated on June 14, with a double pair of planes placed at distances of 2, 4, and 6 inches apart. The detailed observations are given in Table VIII. The times of falling are plotted in Fig. 4. The soaring speeds are plotted in Fig. 5, without attempting to smooth out the

FIG. 5.

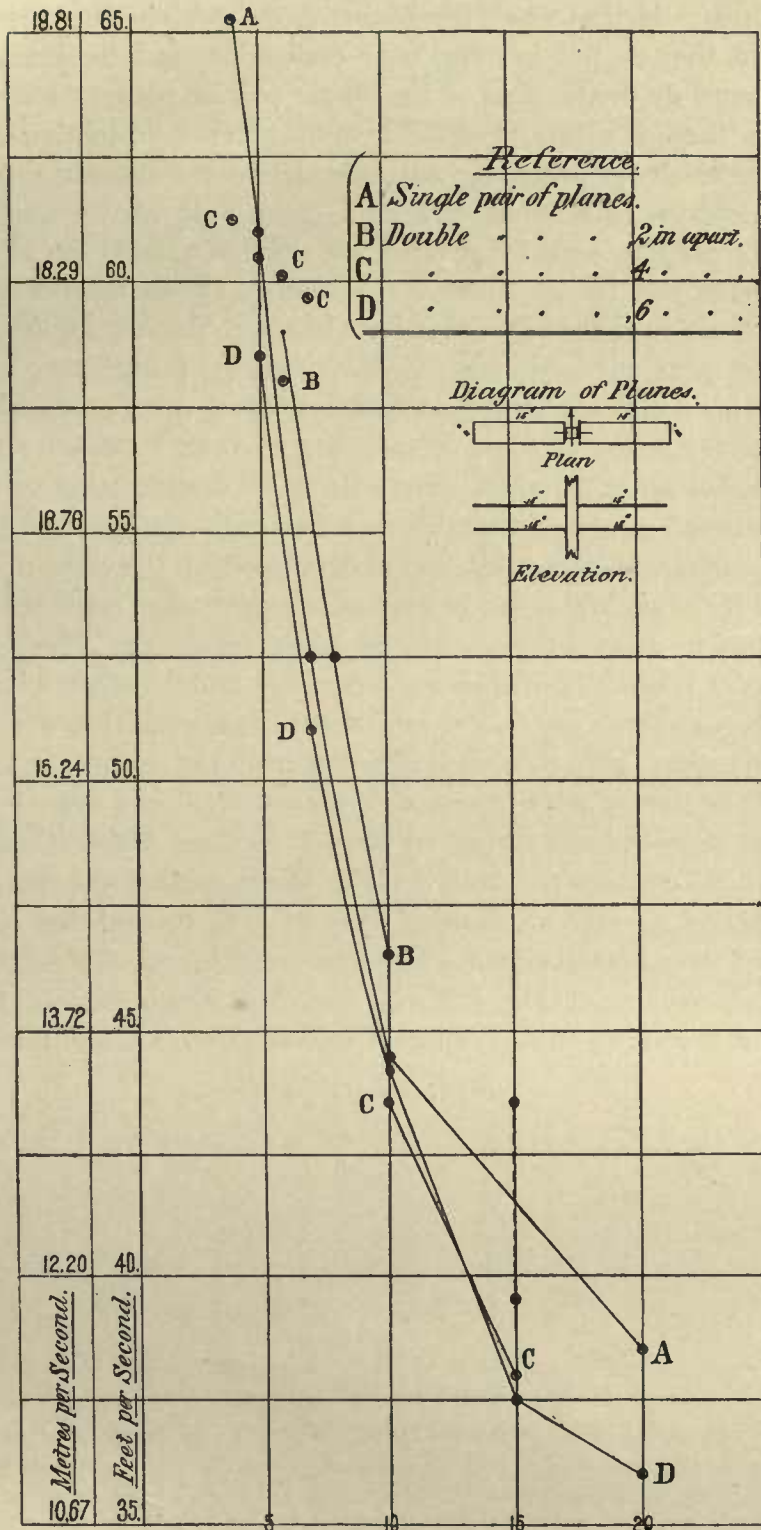

Velocities of soaring of single and double pairs of 15 x 4 inch inclined planes on the *Plane-Dropper*.

Abscissæ: = Angles of inclination (α) of plane to horizon.

Ordinates: = Velocities in meters per second and feet per second.

inaccuracies of observation. The general result presented by both the falling and soaring planes is that when the double pairs of planes are placed 4 inches apart, or more, they do not interfere with each other, and the sustaining power is, therefore, sensibly double that of the single pair of planes; but when placed 2 inches apart, there is a very perceptible diminution of sustaining power shown in the higher velocity required for support and in the greater rapidity of fall. Manifestly, however, this result can hold good only above some minimum velocity of translation, and, in general, we may say that the closeness with which the planes can be set without producing any diminution of sustaining efficiency is a function of the velocity of translation, so that the higher the velocity, the greater the proximity. It was desired, therefore, to ascertain the minimum velocity for which the preceding conclusion holds good, namely, that planes 4 inches wide do not suffer any loss of sustaining power if placed one above the other and 4 inches apart. Experiments with these double pairs of planes were, therefore, continued on August 22, 23, and 24 for the purpose of getting these data. The same planes were used and were placed at the same distance apart, viz., 2, 4, and 6 inches, and a set of experiments was also made with the single pair. Previous to these experiments at high speeds the *Plane-Dropper* was stiffened in order better to preserve its verticality under strong wind pressures, and precaution was taken to observe how closely this condition was maintained. The new observations were somewhat different from the early ones, and consisted in measuring the time of fall of the double planes—*i. e.*, one over the other when set at different angles ranging from -7° to $+7^{\circ}$ at three different velocities, viz., 23.5, 13.0, and 6.5 meters per second. For every setting the brass frame was turned on its pivot through an angle of 180° , so as to present first one side then the opposite as the advancing face. The two positions are designated by A and B in the accompanying Tables, IX, X, and XI, which contain 125 separate observations at the above-named different velocities, angles, and settings.

Experiments to determine the time of falling of two sets of planes, one above the other (second series).

TABLE IX.—AUGUST 22, 1889.

F. W. VERY, *Conducting experiments.*

Barometer, 731.8 mm.; mean temperature, 23°.9 C.; wind, light.

Dimensions and aspect of planes.	Position of falling-piece.	Angle of elevation.	Time of one revolution of turntable (seconds).	Horizontal velocity (meters per second).	Time of fall (seconds).	Remarks.
 <p>15 x 4 inches (38.1 x 10.2 cm.). Double pair of planes. 4 inches apart. Total weight, 942 grammes.</p>	A	0°	0.0	0.69	
	B	0	0.0	0.62	
	A	0	2.60	23.7	1.68	
	B	0	2.65	23.3	1.70	
	B	0	2.60	23.7	1.70	
	B	-2	2.65	23.3	0.70	
	B	-2	2.65	23.3	1.00	
	A	-5	2.60	23.7	0.75	
	A	-5	2.50	24.6	0.50	
	A	+1	2.50	24.6	2.20	Fell, then soared.
	A	+1	2.65	23.3	6.15	Fell slowly.
	B	-1	2.65	23.3	0.90	
	B	-1	2.65	23.3	1.20	
	Same planes, 2 inches apart.	A	0°	2.35	26.2	1.60
B		0	2.45	25.1	1.20	
A		0	2.60	23.7	1.90	
B		0	2.60	23.7	1.30	
A		+2	2.95	20.9	4.15	Soared, then fell.
B		-2	2.75	22.4	0.70	
A		+2	2.70	22.8	5.80	Gradual fall, but very slow.
B		-2	2.65	23.3	0.72	
A		+3	2.60	23.7	Stayed at top.
B		-3	2.65	23.3	0.70	
B		-3	2.75	22.4	0.50	
Same planes, 6 inches apart.	A	0°	3.30	18.7	1.70	
	B	0	3.30	18.7	1.20	
	A	0	3.35	18.4	1.50	
	B	0	3.30	18.7	1.30	
	A	+1	3.00	20.5	14.80	Fell very slowly.
	B	-1	2.95	20.9	1.00	
	A	+1	3.00	20.5	14.20	Fell very slowly.
	B	-1	3.00	20.5	1.10	
	B	-3	3.15	19.6	0.75	
	B	-3	3.20	19.2	0.75	

Result: It is certain that any angle greater than + 1° (with planes 6 inches apart) would produce soaring, and as the error of verticality in this day's observations probably does not exceed 1° during motion, we may take about 2° as the soaring angle for the speeds used.

TABLE X.—AUGUST 23, 1889.

Barometer, 732.3 mm.; mean temperature, 22°.8 C.; wind, light.

Dimensions and aspect of planes.	Position of falling piece.	Angle of elevation.	Time of one revolution of turntable (seconds).	Horizontal velocity (meters per second).	Time of fall (seconds).	Remarks.
 <p>15 x 4 inches (38.1 x 10.2 cm.). Double pair of planes, 6 inches apart. Total weight, 942 grammes.</p>	A	0°	7.80	7.9	0.80	
	B	0	9.30	6.6	0.70	
	A	0	9.10	6.8	0.70	
	B	0	8.45	7.3	0.65	
	A	0	4.80	12.8	1.08	
	B	0	4.80	12.8	1.02	
	A	0	4.85	12.7	0.90	
	B	0	5.00	12.3	1.20	
	A	+ 5	4.95	12.4	1.55	
	A	+ 5	10.05	6.1	0.70	
	B	- 5	9.35	6.6	0.60	
	B	- 5	4.70	13.1	0.64	
	B	+ 5	4.75	13.0	2.10	
	B	+ 5	9.00	6.8	0.78	
	A	- 5	8.10	7.6	0.69	
	A	- 5	4.75	13.0	0.70	
	A	+ 7	4.85	12.7	11.15	
	A	+ 7	8.20	7.5	0.90	
	B	- 7	9.35	6.6	0.62	
	B	- 7	4.70	13.1	0.58	
B	+ 7	4.70	13.1	7.25		
B	+ 7	9.10	6.8	0.80		
A	- 7	9.50	6.5	0.60		
A	- 7	4.75	13.0	0.57		
A	+ 10	4.65	13.3	Soars.	
A	10	7.90	7.8	1.10		
B	10	10.25	6.0	0.75		
Same planes, 4 inches apart.	A	0°	11.55	5.3	0.62	
	B	0	8.60	7.2	0.60	
	A	0	4.60	13.4	0.95	
	B	0	4.70	13.1	0.89	
	B	+ 5	10.10	6.1	0.69	
	B	+ 5	4.70	13.1	2.30	
	A	- 5	4.70	13.1	0.70	
	A	- 5	10.20	6.0	0.65	
	A	+ 5	7.65	8.1	0.63	
	A	+ 5	4.70	13.1	2.90	
	B	- 5	4.80	12.8	0.59	
	B	- 5	10.50	5.9	0.59	
	A	+ 7	13.70	4.5	0.59	
	A	+ 7	4.85	12.7	3.07	
	B	- 7	4.87	12.7	0.58	

TABLE X.—AUGUST 23, 1889—Continued.



Dimensions and aspect of planes.	Position of falling piece.	Angle of elevation.	Time of one revolution of turntable (seconds).	Horizontal velocity (meters per second).	Time of fall (seconds).	Remarks.	
 <p>15 x 4 inches (38.1 x 10.2 cm.). Double pair of planes, 4 inches apart. Total weight, 942 grammes.</p>	B	- 7°	11.70	5.3	0.58	Soars.	
	B	+ 7	11.40	5.4	0.69		
	B	+ 7	4.85	12.7	2.80		
	A	- 7	4.90	12.6	0.58		
	A	- 7	11.40	5.4	0.58		
	A	+ 10	8.60	7.2	0.80		
	A	+ 10	4.70	13.1		
	B	+ 10	11.00	5.6	0.60		
	Same planes, 2 inches apart.	A	0°	11.40	5.4		0.58
		B	0	11.00	5.6		0.56
		A	0	4.90	12.6		0.69
		B	0	4.80	12.8		0.68
		A	+ 5	4.50	13.7		1.13
		A	+ 5	10.30	6.0		0.60
B		- 5	9.20	6.7	0.55		
B		- 5	4.80	12.8	0.55		
B		+ 5	4.90	12.6	0.74		
B		+ 5	9.70	6.4	0.60		
A		- 5	9.90	6.2	0.56		
A		- 5	4.95	12.4	0.60		
A		+ 7	4.95	12.4	1.50		
A		+ 7	11.00	5.6	0.50		
B		- 7	10.60	5.8	0.52		
B		- 7	4.80	12.8	0.50		
B		+ 7	4.60	13.4	1.30		
B		+ 7	9.10	6.8	0.60		
A		- 7	8.75	7.0	0.54		
A		- 7	4.90	12.6	0.58		
A	+ 10	4.80	12.8	3.45			
A	+ 10	10.60	5.8	0.60			
B	+ 10	10.20	6.0	0.61			
B	+ 10	4.90	12.6	1.70			
A	+ 11	4.90	12.6	11.30	Falls slowly.		
A	+ 12	4.90	12.6	27.50	Falls very slowly.		
A	+ 14	4.95	12.4	27.65	Falls very slowly.		
A	+ 14	4.70	13.1	Soars.		
Single pair of planes, 15 x 4 inches (38.1 x 10.2 cm.).	A	0°	4.60	13.4	0.90	[soar. Falls slowly, but does not	
	B	0	4.60	13.4	0.99		
	B	0	8.45	7.3	0.64		
	A	0	8.40	7.3	0.65		
	A	+ 5	8.45	7.3	0.69		
	A	+ 5	5.00	12.3	1.37		
	A	+ 7	5.00	12.3	2.50		
	A	+ 7	8.40	7.3	0.68		
	A	+ 10	7.90	7.8	0.79		
	A	+ 10	5.00	12.3	11.20		

TABLE XI.—AUGUST 24, 1889.

Barometer, 734.3 mm.; mean temperature, 25°.0 C.; wind, light.

Dimensions and aspect of planes.	Position of falling piece.	Angle of elevation.	Time of one revolution of turntable (seconds).	Horizontal velocity (meters per second).	Time of fall (seconds).	Remarks.
Single pair of planes, 15 x 4 inches. 	A	- 5°	9.50	6.5	0.60	Fell after soaring about 20 seconds.
	B	+ 5	9.50	6.5	0.65	
	B	+ 5	5.00	12.3	1.30	
	A	- 5	4.95	12.4	0.60	
	A	- 7	4.85	12.7	0.50	
	A	- 7	8.65	7.1	0.60	
	B	+ 7	9.40	6.6	0.70	
	B	+ 10	8.75	7.0	0.70	
	B	+ 10	4.95	12.4	1.85	
	B	+ 12	5.00	12.3	2.70	
	B	+ 14	5.10	12.1	1.60	
	B	+ 14	4.50	13.7		
	A	0	2.63	23.4	2.60	
	B	0	2.64	23.3	1.07	
	A	0	2.60	23.7	1.80	
	B	0	2.60	23.7	1.00	
	A	+ 1	2.60	23.7	
	B	- 1	2.65	23.3	1.00	
	B	+ 1	2.60	23.7	4.30	
	A	- 1	2.58	23.9	1.10	
A	- 5	2.60	23.7	0.70		
B	- 5	2.60	23.7	0.60		

The actual velocities obtaining in the individual observations varied somewhat; for the lowest velocity ranging between 5 and 8; for the second velocity ranging between 12.5 and 13.5, and for the highest velocity ranging in general between 22.5 and 24.0, except for the planes 6 inches apart, for which the velocities were about 19 meters per second. The numerical results for the lowest and the highest speed will be found plotted in Figs. 6 and 7, respectively. In these diagrams the abscissæ are angles of inclination of the planes to the horizon, and the ordinates are times of falling. For the highest velocity, the times of falling of the single pair of planes and of the double pair, both, 4 inches and 6 inches apart, are alike, while for the planes 2 inches apart, the time of falling is shorter. For the lowest velocity, viz., 6.5 meters per second, the planes 4 inches apart as well as those 2 inches apart fall a little faster than the single plane, and are therefore not quite so well sustained by the air.

This result confirms the statement above made, that for double sets of planes, one above the other, the maximum supporting effect relatively to the single

planes is obtained only above a certain minimum velocity of translation. For the present planes, of size 15 x 4 inches set 4 inches apart, this minimum velocity is shown by the curves to be higher than 6.5 and less than 23.5 meters per second, and, from comparison of all the data, apparently lies at about 13 meters per second. These results substantially confirm those obtained from the experiments of June 14, with this additional information as to the minimum velocity at which the maximum sustaining power can be obtained for a distance apart of 4 inches. For a distance of 2 inches apart even the highest velocities show a serious diminution of efficiency.

The results of these observations with two sets of planes, one above the other, give us a first conception of the form and initial vertical amplitude of the wave that is set in motion in the air by a plane passing horizontally through it in the manner of these planes.

FIG. 6.

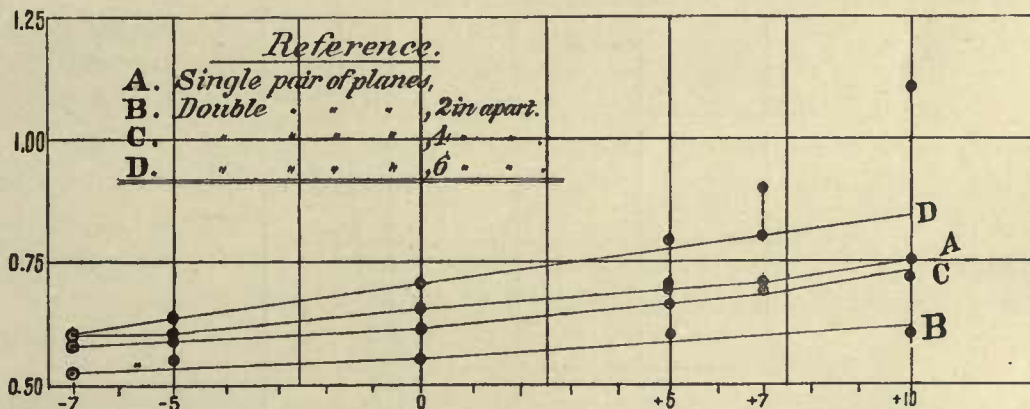

Times of falling 4 feet of single and double pairs of 15 x 4 inch planes set at different angles of elevation and having a horizontal velocity of 6.5 meters per second.

Abscissæ: = Angles of inclination of plane to horizon.

Ordinates: = Time of fall in seconds.

These later observations also incidentally furnish additional data as to the velocity of soaring. When inclined at an angle of 10° the single planes and the double planes, at a distance of 4 inches apart and upward, are sustained in the air if they have a horizontal velocity of about 13.2 meters per second. When set at 1°, soaring took place at velocities from 21 to 23 meters per second. Close observation also indicated that the error of verticality of the plane-dropper during motion did not exceed 1°; hence for these velocities the soaring angle may be taken at about 2°. This is a fraction of a degree less than that given by the observations of June 14, as plotted on Fig. 3.

The most general and perhaps the most important conclusion to be drawn from them appears to be that the air is sensibly disturbed under the advancing plane

FIG. 7.

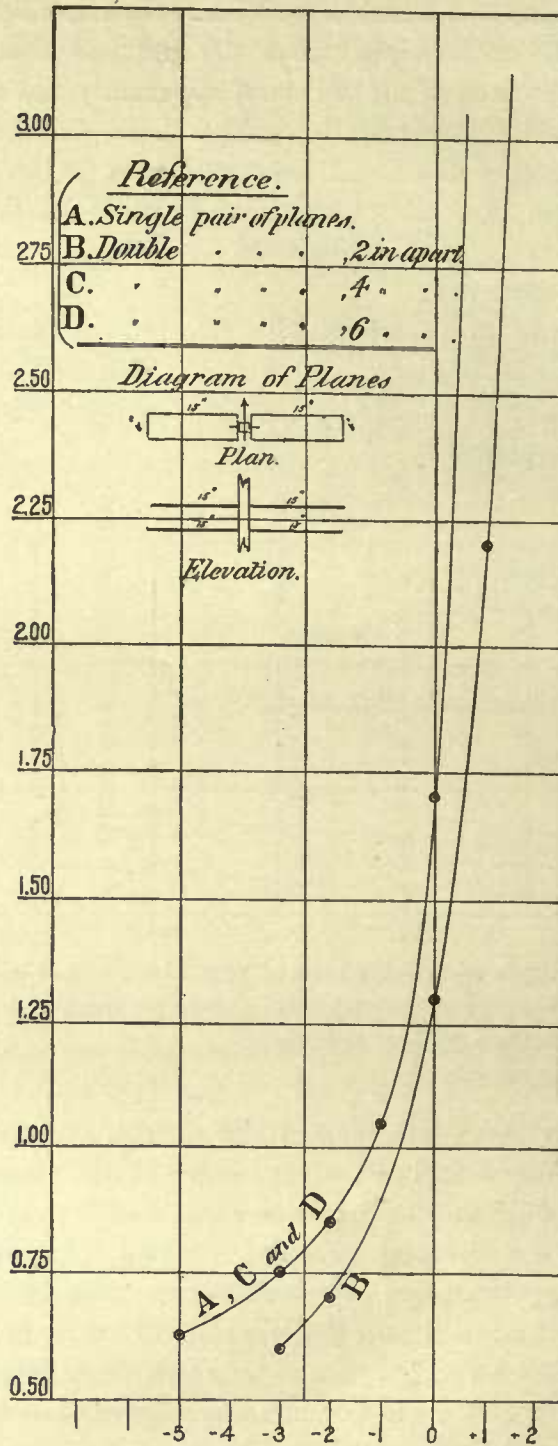

Times of falling 4 feet of single and double pairs of 15 x 4 inch planes set at different angles of elevation and having a horizontal velocity of 23.5 meters per second.

Abscissæ: = Angles of inclination (α) of plane to horizon.

Ordinates: = Time of fall in seconds.

for only a very slight depth; so that for the planes 4 inches apart, at the average speeds, the stratum of air disturbed during its passage over it, is, at any rate, less than 4 inches thick. In other words, the plane is sustained by the compression and elasticity of an air layer not deeper than this, which we may treat, for all our present purposes, as resting on a *solid support* less than four inches below the plane. (The reader is again reminded that this sustenance is also partly due to the action of the air *above* the plane.)

Summing up the results obtained with the plane-dropper, we have determined:

1. The relative times of falling a distance of 4 feet ($1^m.22$) that obtain for differently shaped but horizontally disposed planes moving with different horizontal velocities, showing quantitatively the primary fact that the time of fall is an increasing function of the velocity of *lateral* movement.

2. The varying velocities of translation at which planes of given size and weight, but of different shapes, will be sustained by the air when inclined at different angles.

3. The maximum proximity at which successive planes can be set one above the other in order to give a supporting power proportional to their surface.

4. A first approximation to the initial amplitude of the wave motion originated by a plane passing horizontally or at a small angle through the air with a considerable velocity.

5. The approximate resistance to advance of a wind-plane at soaring speeds, and (by computation) the work necessary to be expended in overcoming this resistance.

These experimentally show that the higher horizontal speeds are maintained with less expenditure of power than lower ones, and the quantitative experiments by which these results are established are, so far as I am aware, new, and I believe have a most immediate bearing on the solution of the problem of artificial flight.

I may add that these experiments with the horizontal plane, when properly executed, give results of a character to forcibly impress the spectator; for, since there is no inclination, there is no visible component of pressure to prolong the fall, yet the plane nevertheless visibly behaves as if nearly deprived of its weight. The pair of 18 x 4 inch planes, for instance, $\frac{1}{16}$ of an inch thick and weighing 464 grammes, has a specific gravity of about 1,660 times that of air; yet while the retardation due to the still air in the direct fall is but $0^s.03$, that due to the same air in strictly lateral motion is $1^s.50$ —a most noteworthy result in its bearing on the use in mechanical flight that may be derived from a property of the air much utilized by nature, but hitherto almost wholly neglected in this connection by man—its inertia.

CHAPTER VI.

THE COMPONENT PRESSURE RECORDER.

The experiments with the *Plane-Dropper* in the preceding chapter give the soaring speeds of wind-planes of different shapes set at varying angles, and enable us by the use of a fundamental formula of mechanics to make a provisional computation of the work expended per minute in their uniform horizontal flight, neglecting frictional resistances.

Among several conclusions, one of prime importance, namely, that in such aerial motion of heavy inclined planes the higher speeds are maintained with less expenditure of power than the lower ones, presents an appearance so paradoxical that, in view of its obviously extraordinary importance, I have endeavored to establish it independently wholly by experiment, without the use of any formula whatever. For this purpose it is desirable to measure by means of a suitable dynamometer the number of foot-pounds of work done in overcoming the resistance to advance when a wind-plane is driven at soaring speeds (*i. e.*, speeds at which it maintains a horizontal course by virtue of the vertical component of pressure, which in this case is just equal to the weight), by means of the whirling table, yet under conditions strictly assimilable to those of free flight, in the case of an actual aerodrome propelled by its own motor.

After much study and much experiment, I gradually perfected an instrument (that described here as the *Component Pressure Recorder*), to be used in connection with the *Dynamometer-Chronograph* in recording the speed, the resistance to forward motion at the instant of soaring, and other attendant phenomena. Its use in connection with the *Dynamometer-Chronograph* will also be further described in chapter VII.

In the present chapter, I shall not consider further the action of the self-propelling model, but treat of it as reduced to its simplest type of an inclined plane, the "wind-plane," or system of planes driven forward by the turn-table arm until they are raised from it by the wind of rotation and *soar*. The immediate objects of experiment are, therefore, to determine soaring speeds and the horizontal resistances corresponding thereto.

DESCRIPTION.

The *Component Pressure Recorder* (or *Component Recorder*), plate VII, may be compared to a balance which rocks on a knife-edge bearing, in the ordinary way, but which also oscillates horizontally about a vertical axis. With respect

to its vertical oscillations about the knife-edge bearing, it is a true balance, whose arms, each one meter long, are in delicate equilibrium; and I will call this part of the instrument distinctively "the balance."

If an actual working aerodrome model with its motor be not used upon the outer arm (outer, that is, as reckoned from the center of the turn-table), a plane of given weight (the "wind-plane") is clamped there, so as to make any desired angle of inclination with the horizon. The horizontal oscillation about the vertical axis provides for the measurement of the horizontal component of pressure on this plane; the vertical oscillation on the knife-edge provides for measuring the vertical component. The horizontal pressure is measured by the extension of a spring fastened to an arm moving around the axis with the horizontal oscillation of the balance, and to the surrounding fixed frame. The vertical component of pressure is measured only when it is equal to the weight of the plane—*i. e.*, by the fact that the plane is actually just lifted by the wind of rotation, or, in the technical term previously used, when it *soars*. The requisite registration of this fact is automatically accomplished by making an electric contact. As the wind-plane is raised, the inner end of the balance descends, until it strikes a stop through which electric connection is established, and the "making" of the current is registered on the stationary chronograph, which at the same time records the speed of the whirling table four times in each revolution, and thus the horizontal velocity which produces a vertical pressure sufficient to lift or sustain the wind-plane is determined.

The detailed manner in which these objects are attained by the apparatus is described later in the text, and is shown by the drawings of plate VII. The letters S designate the iron supports by means of which the frame of the recorder rests upon the arm of the whirling table in such a manner that the instrument is half above and half below it. The knife-edge and the wind-plane are brought thereby into the plane of rotation, and equal surfaces above and below the supporting arm of the whirling table are exposed to the wind pressure.

The details of the knife-edge bearings are shown on the plate in enlarged scale. It is evident that when the balance resting on its knife-edge is in motion on the whirling table, there will be an outward thrust on the instrument tending to throw the knife-edge off from its bearing. In order to take up this thrust, and yet in no way impair the action of that portion of the instrument which acts the part of a balance, a pair of cylindrical pivots exactly concentric with the prolongation of the knife-edge are made to extend out beyond the knife-blade and rest in a suitable bearing. The pivots thus arranged take up the outward thrust arising from centrifugal force, while the freedom of motion of the balance on the knife-edge is not at all impaired.

The wind-plane is fastened to a brass tube on the outer end of the instrument, and set to any angle of inclination by means of the graduated circle G. This tube is adjustable in position so that the center of the wind-plane, whatever be its size, is at a constant distance of 1.25 meters from the center of the balance and of the whole instrument. A similar adjustable tube on the inner arm serves to adjust the balance to equipoise for any position of the outer tube. Beneath the inner arm of the balance a registering arm is rigidly fastened to the vertical axis, and partakes of the horizontal oscillation of the balance, but not of its vertical motion. Near its extremity is attached the horizontal spring already referred to, and at the end it carries a pencil, which registers on a revolving chronograph cylinder below the extension of the spring produced by the horizontal pressure on the wind-plane.

The length of the record arm from center of balance to spring is 28.5 inches, (72.4 cm.)

The length of the record arm from center of balance to pencil is 31.5 inches, (80.0 cm.)

The pencil departures are therefore longer than the true spring extension, and the latter are obtained from the former by multiplying by the factor $\frac{28.5}{31.5} = 0.905$.

To reduce the pull on the spring to what it would be if the spring had the same lever arm as the center of the plane, we must multiply it by the factor expressing the ratio of the lengths of the arms, viz., $\frac{72.4}{125.0} = 0.579$.

Within the limits of attainable precision, we observe the spring calibration to be linear, and the two factors may be multiplied together, giving the single factor 0.524, by which the pressure corresponding to pencil departures, as taken from the calibration curves, must be multiplied in order to get the pressures on the plane. The horizontal springs used in these experiments are those hereafter more fully described in connection with the *Rolling Carriage*.

The uniform distance from the center of rotation of the turn-table to the center of wind plane is 9.55 meters. The balance arms are protected from wind by covering the sides of the surrounding frame with cloth and paper and placing over the top an adjustable lid of veneer. An experimental test of the *Recorder* without wind-plane was first made, to discover the effect of any residual wind pressure on the arms. The instrument was carefully adjusted on the turn-table, and then set in rapid, uniform motion without exhibiting any tension of the horizontal spring. The result indicates that whatever wind pressure still remains is equal on both arms. It is to be noted that a theoretically perfect measurement of horizontal wind pressure by this instrument requires a uniform

velocity of the turn-table at the instant for which the reading is made. The occasion for this condition arises in the circumstance that with a varying velocity the inertia of the inner arm of the balance produces a different effect on the instrument from the inertia of the outer arm; thus with increasing velocities the outer arm tends to go slower than the inner arm, and with decreasing velocities tends to go faster. This differential effect of inertia is taken up by the spring and is combined with the wind pressure until a uniform velocity is attained, and then the wind pressure alone remains to extend the spring.

Each arm of the balance carries a brass friction wheel, *R*, which is intended to rest upon a track, *P P'*, thereby limiting the vertical motion of the balance arms. When the wind-plane is vertical, and horizontal wind pressure is being measured, the outer arm carrying the plane rests continuously on the track and the friction wheel affords perfect freedom of horizontal motion of the balance, which fulfills its proper function at the same time that it turns about the vertical axis; so that when the plane is inclined and is raised by the vertical component of the wind—*i. e.*, when the wind-plane *soars*—the inner arm is brought down to the stop *P* and the friction wheel insures free motion of the balance about the vertical axis. An electric wire connects with *P*, and a second wire carries a current through the knife-edges into the balance, and thence to the friction wheel, where the electric current is completed at the moment of contact between the friction wheel and the stop. After leaving the whirling table the current passes through an electric bell, which serves to inform the experimenter of the fact of *soaring* (though this is independently recognizable by the motion of the arm), and thence to the observatory chronograph, where the contacts are registered. On this chronograph, then, are registered (1) the second-beats of the mean time standard clock of the observatory; (2) the contacts, which are made four times in every revolution of the turn-table and show its speed, and (3) the electric current which registers *soaring*; the two latter records being clearly distinguishable.

The actual method of experiment employed to determine the velocity at which soaring is just attained is as follows: The velocity of the whirling table is increased to the point at which soaring almost begins to take place—that is, when the plane begins to flutter. This velocity is then still further, but very slowly, increased and adjusted until the electric bell rings as nearly as possible half the time. The velocity at which this occurs represents that of soaring. This method is based on the following considerations: If the precise velocity be attained at which the plane would be just sustained in quiet air, not resting on the stop at either end, the actual wind which prevails to a greater or less extent in the open air disturbs this equilibrium and causes the plane to be more than sustained during the half revolution of the turn-table which carries it against

the wind, and less than sustained during the remaining half. Consequently, this condition of electric contact half the time is taken to be the one desired, and the velocity corresponding to it is taken from the chronograph and called the soaring velocity for the plane and angle obtaining in the experiment. When the electric bell indicates to the observer an exact soaring, the speed is maintained uniformly for a few revolutions, as required by the theory of the *Recorder* already alluded to, as a requisite for the proper measurement of the wind pressure on the plane. A brush H is attached to the inner arm of the balance for the purpose of producing a regulated friction, and thereby diminishing somewhat the fluctuations of the apparatus, which was found to be too sensitive to currents to do work of all the accuracy it is capable of, except in calm weather.

Some preliminary experiments were made in August, 1889, to determine the relative velocities of soaring of different planes. But the first *Component-Recorder* was shortly afterwards destroyed in an accident, and the observations were interrupted until September, 1890, when they were resumed with the newly constructed and improved *Component-Recorder* figured in the plate. Nine new planes were made of light pine, and backed with lead so as to have the following sizes and weights:

Size.		Weight.	Size.		Weight.	Size.		Weight.
Inches.	Cm.	Grammes.	Inches.	Cm.	Grammes.	Inches.	Cm.	Grammes.
30 x 4.8	76.2 x 12.2	250	24 x 6	61.0 x 15.2	250	12 x 12	30.5 x 30.5	250
50 x 4.8	76.2 x 12.2	500	24 x 6	61.0 x 15.2	500	12 x 12	30.5 x 30.5	500
30 x 4.8	76.2 x 12.2	1,000	24 x 6	61.0 x 15.2	1,000	12 x 12	30.5 x 30.5	1,000

It was found that the heavier planes, and especially the longer ones, required light trussing in order to prevent them from bending when in rapid motion. This was effected by inserting a transverse arm of round brass in the end of the brass tube where the planes are attached, and carrying fine steel wire out to the extremity of the plane. The 30-inch plane was further trussed by a post at its center carrying wires to the four corners.

Inasmuch as the center of pressure on an inclined plane is in front of the center of figure (as will be shown in connection with the *Counterpoised Eccentric Plane*), the lead backing was inserted to one side of the center, so as to bring the center of gravity into approximate coincidence with the center of pressure when the plane is inclined at low angles, and the plane was grasped at a similar distance in front of the center. These provisions contributed to diminish the twisting of the planes. These planes were used until November 25, when they

were replaced by others backed with strips of brass, which gave the planes the desired weight, and also contributed the necessary stiffness. The latter planes are made of pine $\frac{1}{2}$ of an inch thick, with square-cut edges. The brass strip is a piece of hard-rolled brass running the whole length of the plane, and about 2 inches wide. In the 24 and 30 inch planes the middle of the strips was bent slightly outward—*i. e.*, "corrugated"—for greater stiffness.

The experiments were made in two series. The first series was made on eight days, from September 29 to October 9, inclusive, and consisted in determining the soaring speeds and corresponding resistances of the above-described planes set at angles from 2° to 30° , and the horizontal pressure on the planes when set at 90° —that is, normal to the line of advance. In all, 95 complete observations were taken.

The following is an example of the original record made in these observations, extracted from the note book for October 8 :

Experiments with Component Pressure Recorder to determine horizontal pressures at soaring speeds.

OCTOBER 8, 1890.

F. W. VERY, *Conducting experiments*; JOSEPH LUDEWIG, *Regulating engine*.

Barometer, 736.6; temperature, 15° C.; air meter at 10:30 a. m., 1,509,500; air meter at 3:20 p. m., 1,500,400; 30 x 4.8 inch plane; weight, 500 grammes; spring No. 2.

Angle.	Seconds in one revolution of turn-table.	Velocity of plane (meters per second).	Extension of spring (inches).*	Pull of spring (grammes).
90°	12.10	4.96	1.40	45
	10.05	5.97	2.20	472
	9.60	6.25	2.45	526

*The use of an English scale instead of a metric one in measuring the spring extensions introduces a lack of harmony in the system of units employed that is not to be recommended; but since this is a record of the original observations, the measurements as actually made are faithfully presented.

Angle.	Seconds in one revolution of turn-table.	Estimated soaring speed (meters per second).	Spring extension (inches).	Remarks.
30°	5.5 > 6.3 < 5.5 > 5.75 < 5.55 > } 5.65 secs.	10.6	2.3	
15°	4.8 >> 5.4 > 5.65 right 6.3 << 5.9 < 5.85 right } 5.75	10.4	0.8	Plane quivers at tip with highest speed.
10°	5.0 > 5.4 right 5.85 < 5.5 < 5.3 < 5.3 right } 5.35	17.9	0.75	Plane somewhat bowed.
Plane stiffened by thin iron plate at both ends and at middle, and experiment repeated with same setting.				
10° (Repeated)	4.9 > 5.0 < 4.75 > 5.1 < 5.0 > } 4.95	12.1	0.9	

The extensions of the spring corresponding to the horizontal component of pressure on the plane, and caused by the movement of the *Recorder* about the vertical axis, are taken from the sheet of the recording cylinder carried on the turn-table arm, as already described and as shown on plate 7. The records of velocities are found on the stationary chronograph registering the quadrant contacts of the turn-table, and on the same sheet with the electric contacts made at soaring speeds. Thus, when the latter sheet has been taken off its chronograph barrel, the observer has before him a permanent record of the velocity of the turn-table measured four times in every revolution, and together with it the trace of the irregular contacts made by the vertical rocking of the balance arm which takes place at soaring speed. Now, since the criterion of exact soaring is that these signals shall appear on the trace half the time of each revolution, an inequality mark is added to the record of the measured velocities, which indicates how nearly this condition is attained. If the chronograph sheet for any complete revolution of the turn-table is more than half filled with the signals, the velocity

is too great; if less than half filled, the velocity is too small, etc. Two or more inequality marks are used to indicate a wide difference from the mean condition. By putting down a series of such readings measured at a number of revolutions of the turn-table and taking a mean estimate, a very close approximation to the soaring speed may be made, and the result has the weight of a very considerable number of single readings.

After completing the experiments of September 29 to October 9 according to the plan laid out, the observations were reduced, and their discussion served to show that additional experiments were needed to supplement them. Thereupon a second series was instituted for the purpose of obtaining additional data. In this series the following five planes were used:

Size.		Weight.
(Inches.)	(Centimeters.)	(Grammes.)
30 x 4.8	76.2 x 12.2	500
24 x 6	61.0 x 15.2	500
12 x 12	30.5 x 30.5	500
12 x 6	30.5 x 15.2	250
6 x 6	15.2 x 15.2	125

The principal further objects to be attained were to determine with greater precision the soaring speeds of the 24 x 6 and 30 x 4.8 inch planes at small angles and the horizontal pressure at those speeds; to determine the soaring speed for angles of the plane above 30°, so as to get the minimum point in the soaring speed curve—that is, to determine the angle at which soaring takes place with minimum velocity; and to ascertain the effect of size of plane on soaring speed by adding to the planes previously used two of smaller size, viz., 12 x 6 inches and 6 x 6 inches, having a corresponding diminution of weight. The five planes, therefore, all have sizes and weights in the proportion of 500 grammes to the square foot* (or 5,382 grammes to the square meter), and their soaring speeds are entirely comparable for indicating the relative effect of shape and size. The new observations were carried out on November 25, 26, December 5 and 11, and comprised over 80 individual experiments. The detailed observations of both series are presented in Tables XIV and XV, placed at the end of this chapter.

The column headed "description of planes" gives the dimensions and weight of the planes. The *aspect* of the plane—*i. e.*, its position with respect to the

* The square foot was adopted as a unit in the earliest experiments, and its use has been continued as a matter of experimental convenience, owing to considerations bearing upon the uniformity of apparatus. Were these experiments to be recommenced, I should prefer to use C. G. S. (or at least metric) units throughout.

direction of advance—is indicated by the order in which the dimensions are stated, the first dimension being always the horizontal edge parallel to the whirling arm. Thus the 24 x 6 inch plane is placed with its 24-inch edge horizontal and parallel to the whirling arm, and the 6 x 24 inch plane is the same plane placed with its 6-inch edge horizontal and parallel to the whirling arm. This difference of position, then, will be uniformly spoken of as the *aspect* of the plane. The column “pull of spring” contains the spring extensions converted into pressures by means of the calibration curves, and the column “horizontal pressure on plane” (*i. e.*, the horizontal component of pressure) is obtained by multiplying the spring pressure by the factor 0.524, which arises from the unequal lengths of the arms of the instrument. The next column, headed “ k_m ,” gives for the observations with normal planes the computed value of the coefficient in the equation $P = k_m V^2$, where V is expressed in meters per second, and P is the pressure on the plane in grammes per square centimeter. The column “ k ” gives the corresponding value of this coefficient in English measures, the velocity being expressed in feet per second and the pressure in pounds per square foot.

SOARING SPEEDS.

The soaring speeds determined in these two series of experiments are plotted in Figs. 8 and 9, in which the abscissæ are angles of inclination of the planes to the horizon, and the ordinates are the soaring speeds which correspond to them. Figure 8 contains the observations made with the planes that weigh 250 and 1,000 grammes to the square foot, and Fig. 9 those made with the planes that weigh 500 grammes to the square foot (5,382 grammes to the square meter). The experiments with the first two of these classes of planes, plotted in Fig. 8, were not repeated, and consequently the curves do not possess so high a quantitative value as obtains in the case of most of the planes weighing 500 grammes to the square foot, but they serve to present several fundamental relations:

First, they show quantitatively, when taken together with the curves of Fig. 9, the increase of velocity necessary to sustain the heavier planes (per unit area) over that which will sustain the lighter ones, at the same angle of inclination.

Second, the curves both of the 250 and the 1,000 gramme planes show the difference due to shape and aspect, the soaring speeds, for small angles of inclination, being much less for those planes whose extension from front to back is small, than for those in which this dimension is large, so that, in general, the planes having this dimension smaller, for small angles of inclination, soar at lower speeds. This result entirely accords in character with that already obtained with the *Plane-Dropper*; and, when freed from accidental errors, the present data are of higher quantitative value, because in this apparatus there are no guides, and the plane has practically perfect freedom.

FIG. 8.

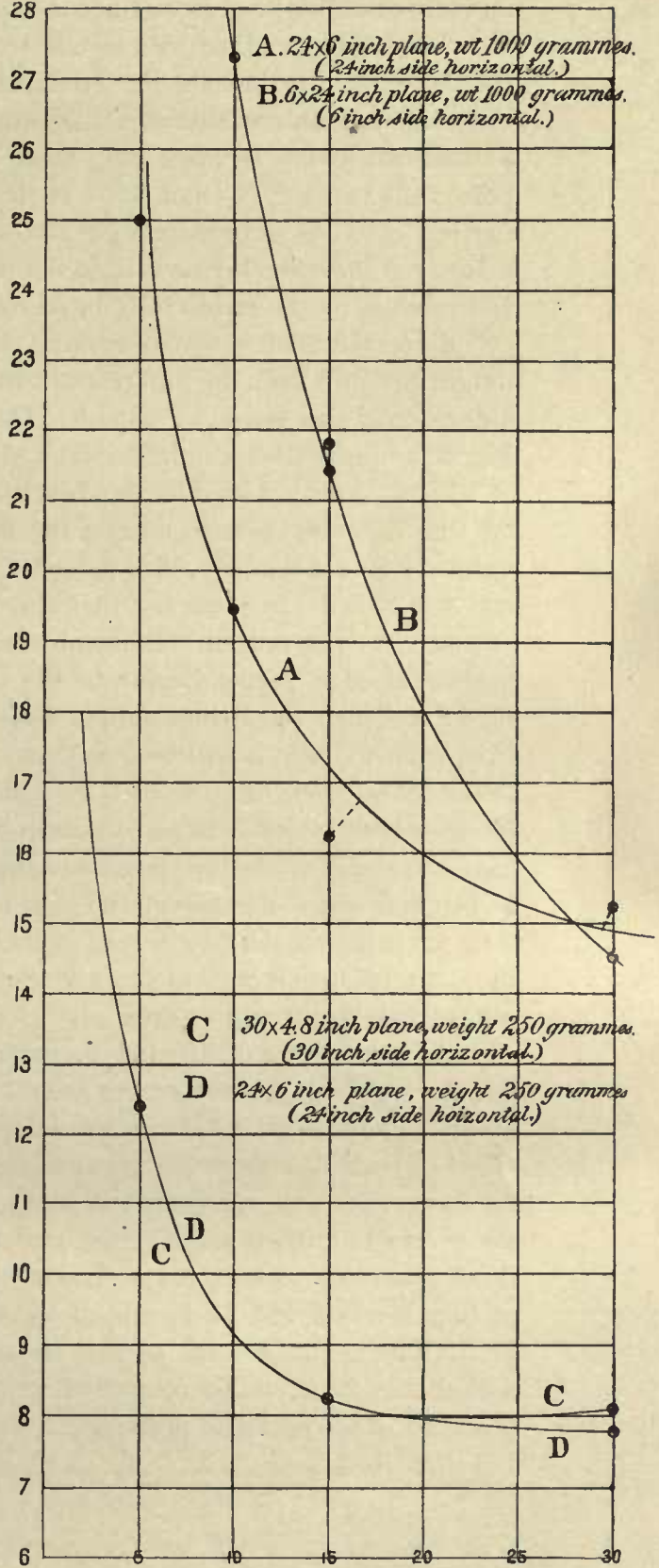
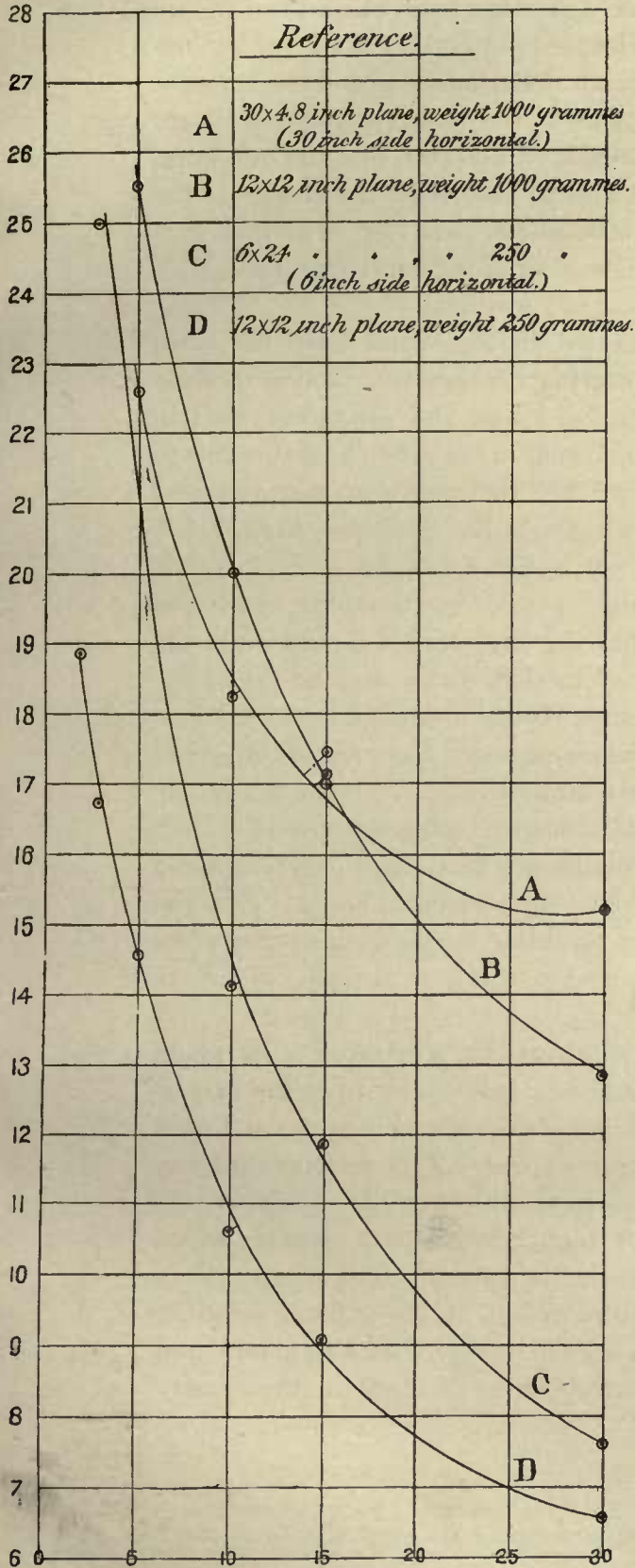

Velocities of soaring of inclined planes obtained with the *Component Pressure Recorder*.
 Abscissæ : = Angles of inclination (α) of plane to horizon.
 Ordinates : = Velocities in meters per second.

Third, many of the curves show a tendency to reach a minimum point for an inclination of the planes of about 30° , the highest angle at which these planes were used. It was, therefore, seen to be desirable to extend the angles of inclination far enough to include the minimum point of the curve within the range of observation. This was done in the case of four of the planes whose results are plotted in Fig. 9. In examining these curves, it will be seen that the minimum point falls between 25° and 35° . It should also be noted that the change in the soaring speed is quite small for settings between 25° and 40° , and that in a number of individual observations the real character of the curve over this range was masked by the errors introduced by wind and weather.

Since the planes whose results are plotted in Fig. 9 all have the same weight per unit area, the difference in their soaring speeds arises solely from their difference of size, shape, or aspect. The effect of shape and aspect indicated in Fig. 8 is beautifully exhibited and amply confirmed in the six comparable curves of Fig. 9. For low angles, viz., below 15° or 20° , the curves of soaring speed for the different planes occupy the following relative positions from below upward: 30 x 4.8 inches, 24 x 6 inches, 12 x 6 inches, 6 x 6 and 12 x 12, 6 x 24 inches. It will be observed that the planes placed in the above order are symmetrically arranged. Remembering that the first written dimension is the horizontal edge, perpendicular to the line of motion, which may be called the *spread*, and that the second written dimension is the inclined edge, or the distance from front to back, it will be seen that, in the above order, the ratio of the *spread* to the extent from front to back is uniformly diminishing. In other words, the planes whose *spread* is largest in comparison with their extent from front to back have the smallest soaring speed, and these planes are therefore to be considered as being, in shape and aspect, the most favorable for mechanical flight. Thus the 30 x 4.8 inch and the 24 x 6 inch planes are favorable forms and aspects, while the 12 x 12 inch plane and, to a greater degree, the 6 x 24 inch plane are unfavorable forms and aspects.

Between 15° and 30° , and in general at about 30° , a reversal takes place, and for higher angles the curves are all found from below upward in the reverse order. Thus the 30 x 4.8 inch plane, which for low angles soars at the lowest speed, for settings above 30° requires the highest speed. This relative efficiency for low angles was manifested in the experiments with the *Plane-Dropper*, but the reversal in the position of the curves for higher angles is a relation which those observations were not sufficiently extended to present. The interpretation of this reversal will be developed by a consideration of the general relations existing between these results and the total normal pressure on the planes, and will also be found to be connected with corresponding changes in the relative positions of the center of pressure.

FIG. 9.

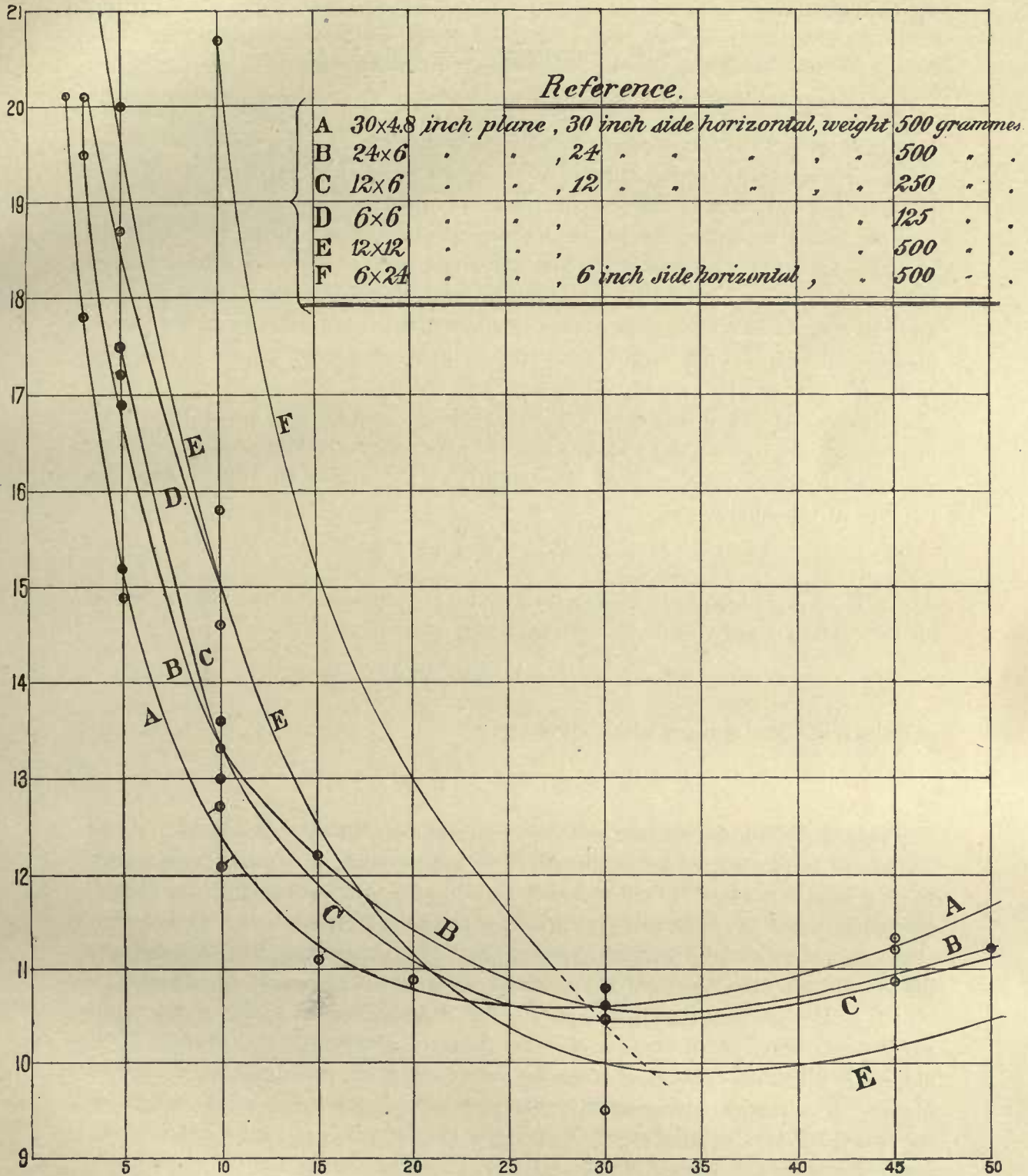

Velocities of soaring of inclined planes obtained with the *Component Pressure Recorder*.
 Abscissæ: = Angles of inclination (α) of plane to horizon.
 Ordinates: = Velocities in meters per second.



The pressure on a plane moving normally in the air is usually represented by the equation

$$P = \frac{k A V^2}{1 + 0.00366 (t - 10^\circ)} \frac{B}{760},$$

where V is the velocity of the plane; A is its area, B the atmospheric pressure in millimeters, t the temperature in centigrade degrees, and k a coefficient whose value for a standard temperature of 10° C. is determined by experiment. If the pressure per unit area is different for planes of different sizes and shapes, it will be manifested by differences in the resulting values of k . Then, if k be given its value for a plane of some fixed size and shape, one or more additional factors must be inserted in order that the formula shall give the pressure on a plane of any other size and shape. Experiments show that the variations in k for planes of different shapes and, within the range of experiment, for planes of different sizes, are very small.

Proceeding now to the case of inclined planes, and for our present purpose neglecting the pressure and temperature, we may represent the resultant pressure P_a on an inclined plane moved horizontally in the air at an angle α with the horizon by the equation

$$P_a = P_{90} F(\alpha) = k A V^2 F(\alpha),$$

where $F(\alpha)$ is a function to be determined by experiment. From this equation also we obtain directly the vertical component of pressure

$$W = P_a \cos \alpha = k A V^2 F(\alpha) \cos \alpha$$

and the horizontal component of pressure

$$R = P_a \sin \alpha = k A V^2 F(\alpha) \sin \alpha.*$$

The point to which I wish now to direct especial attention is that, although shape and aspect of plane have but slight effect on the pressure on normal planes, they have a most important influence in determining the pressure on inclined planes. Consequently, $F(\alpha)$ must be determined separately for planes of different size, shape, and aspect. An empirical curve (Fig. 1) representing $F(\alpha)$ for a square plane has been obtained from the experiments with the *Resultant-Recorder*.

It is obvious that the above equation for W furnishes the basis for determining $F(\alpha)$ for variously shaped rectangles from the observations of soaring speed obtained with the *Component-Recorder*, together with experiments on normal planes. The vertical component of pressure at soaring speed is the weight of the plane, k is the fundamental constant of normal pressure derived from experiments on the normal plane, and V is the soaring speed for the angle α .

**Note to Second Edition.* I do not desire to multiply formulæ where it can be avoided, as this book is meant to be only the statement of facts of observation, but a simple résumé of these facts in algebraic generality would take this form:

$F(\alpha)$ is of the form $C \sin B \alpha^n$ where $n > 1$ in long aspects $\left[\leftarrow \right]$ and $F(\alpha)$ is of the form $C \sin B \alpha^n$ where $n < 1$ in broad aspects $\left[\leftarrow \right]$, where C is a constant and B the angle between the tangent and the vertical.

For the 12 x 12 inch square plane, and for the 30 x 4.8 inch and the 6 x 24 inch planes, which last two are the planes having the extremes of aspect, $F(\alpha)$ has been computed from the above equation for W , and the results are plotted in Fig. 10. In this computation W is 500 grammes; V is taken from the soaring speed curves for successive values of α , and the adopted value of k_m , viz., 0.0080, in metric units, is the mean value given by the normal planes in these experiments. Comparing the resulting curve for the 12-inch square plane with the curve derived from the experiments with the *Resultant Pressure Recorder*, we find the following values:

TABLE XII.

$F(\alpha)$, or the ratio of the pressure on an inclined plane one foot square, to the pressure on the same normal plane.

Angle of inclination α .	From the <i>Resultant-Recorder</i> (directly from experiment).	From the <i>Component-Recorder</i> (computed from experiment by above formula).	Difference.
45	93	91	+ .02
40	89	88	+ .01
35	84	84	.00
30	78	78	.00
25	71	69	+ .02
20	60	57	+ .03
15	46	44	+ .02
10	30	30	.00
5	15	16	- .01

The agreement between these values of $F(\alpha)$ derived from these two entirely dissimilar methods of observation (dependent also, as it is, on the experimental value of k_m) bespeaks the essential harmony of the entire system of results. If, now, the curves of soaring speed have been determined for the 30 x 4.8 inch and 6 x 24 inch planes with the same degree of accuracy as for the 12-inch square plane, the computed values of $F(\alpha)$ for these planes has the same precision as that for the 12-inch square plane.

Looking at the curves, we find that for small angles the resultant normal pressure is greatest in the 30 x 4.8 inch plane and least on the 6 x 24 inch plane; but for angles above 30° this relation is reversed.

The reversal in the relative positions of the curves of soaring speed at an angle of inclination of about 30°, for differently shaped planes, is now seen to

FIG. 10.

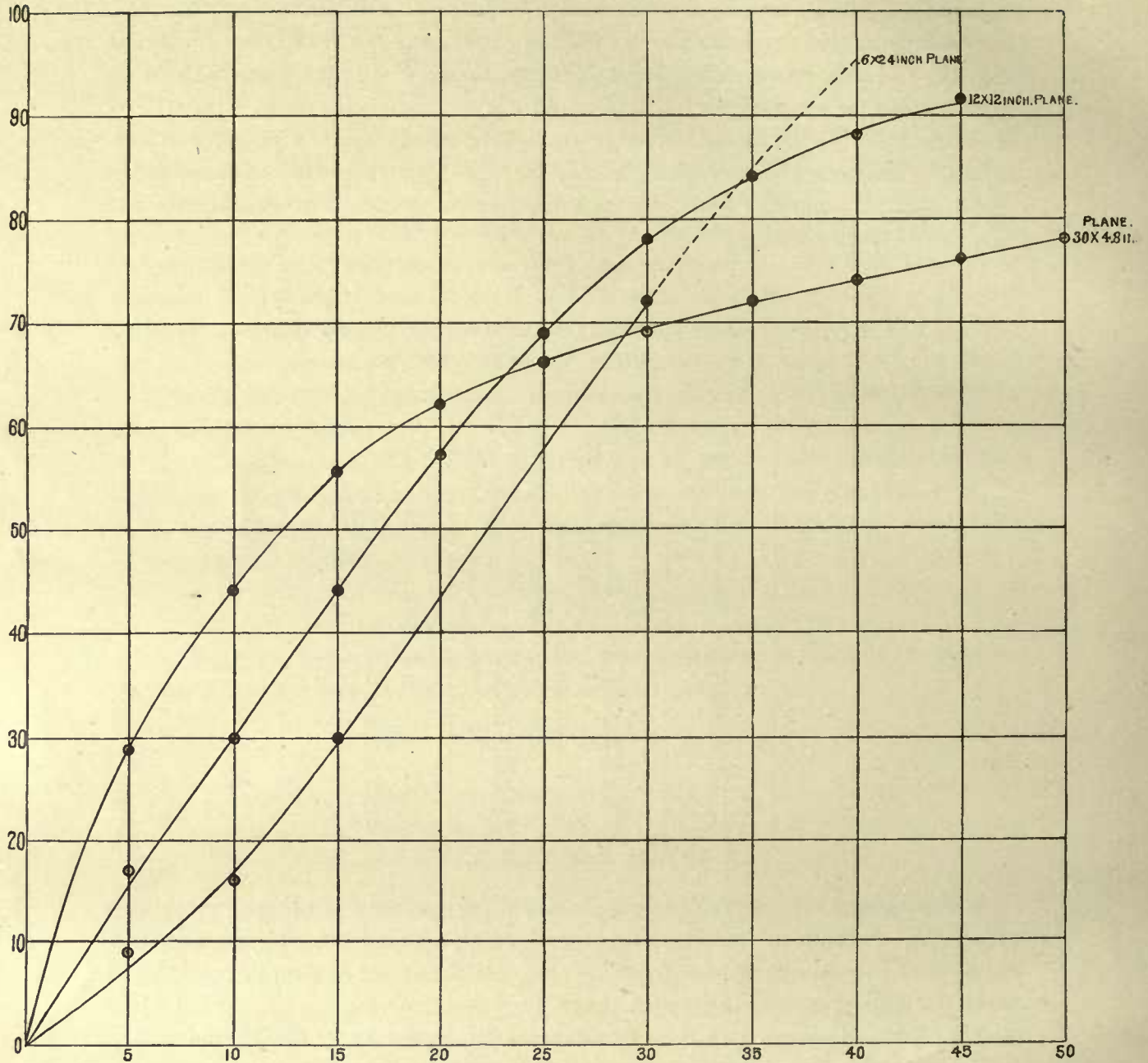

Ratio of the resultant normal pressure (P_a) on an inclined rectangle to the pressure (P_{90}) on a normal rectangle, computed from experiments with the *Component Pressure Recorder*.

Abscissæ: = Angles of inclination (α) of plane to horizon.

Ordinates: = $F(\alpha) = \frac{W}{k A V^2 \cos \alpha} = \frac{P_a}{P_{90}}$ (expressed as a percentage).

be due to a reversal in the total normal pressure on the planes.* Thus, shape and aspect of plane, while having but slight influence in modifying the pressure when the plane itself is normal to the wind, are most important factors when the plane is inclined. This predominating influence of *aspect* is, so far as I am aware, now for the first time clearly set forth with quantitative data.†

HORIZONTAL PRESSURES.

With every observation of soaring speed, the horizontal pressure on the plane has been measured by means of a horizontal spring. The detailed observations in Tables XIV and XV contain the number of the spring used, the extension of the spring as measured on the trace in inches, the corresponding pull of the spring, measured in grammes, as taken from the calibration curves, and, lastly, the computed pressure on the plane, obtained by multiplying the pull of the spring by the factor 0.524, which reduces the effect of the actually unequal arms of the instrument to what it would have been were the arms equal. For angles of 90° the instrument affords an additional method of determining the constant of normal pressure, and for all these observations the resulting values of k_m and k have been computed. As previously used, the numerical value of k relates to velocities expressed in feet per second and pressure in pounds per square foot, and k_m relates to velocities expressed in meters per second and pressures expressed in grammes per square centimeter.

The horizontal pressures on the inclined planes diminish with decreasing angles of elevation, and for angles of 5° and under are less than 100 grammes. Now, for a pressure less than 100 grammes, or even (except in very favorable circumstances) under 200 grammes, the various errors to which the observations are subject become large in comparison with the pressure that is being measured, and the resulting values exhibit wide ranges. In such cases, therefore, the measured pressures are regarded as trustworthy only when many times repeated. On the 30 x 4.8 inch plane, weight 500 grammes, fifteen observations of horizontal pressure have been obtained at soaring speeds. These values have been plotted in Fig. 11, and a smooth curve has been drawn to represent them as a whole. For angles below 10° the curve, however, instead of following the measured pressure, is directed to the origin, so that the results will show a zero horizontal

* For a further analogy with a corresponding reversal in the position of the center pressure, see Appendix C.

† Only after completing these experiments has my attention been called to those of Hutton, who appears to have been the first to make experiments in this field, in 1787, and who, it is interesting to see, appreciated the necessity of examining this question of aspect. He tried a plane 8 x 4 inches with both the long edge and the short edge in the direction of the arms of his whirling machine, but failed to obtain any sensible difference in his resulting horizontal pressure, probably because the friction of his apparatus swallowed up the small differences that exist in the horizontal component of the pressure at small angles. If he had measured the total pressure or the vertical component, he would probably have discovered a difference in the two cases. I also find that while my experiments have been in progress, Mr. W. H. Dines has likewise been investigating the effect of *aspect*, at Hershham, England, with results similar to my own.

FIG. 11.

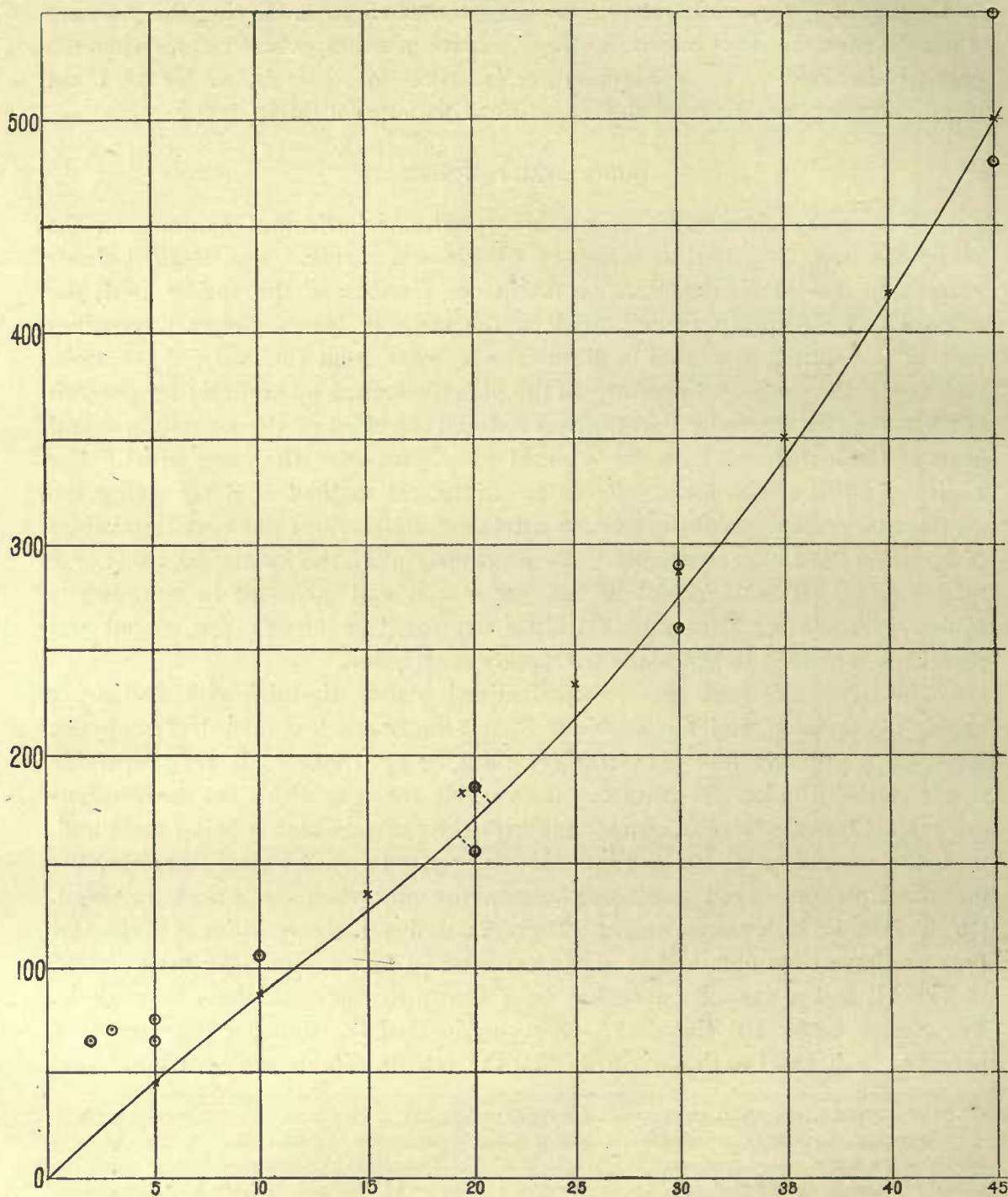

Horizontal pressure (or resistance to advance) on 30 x 4.8 inch plane at soaring speeds obtained with the *Component Pressure Recorder*.

Abscissæ: = Angles of inclination (α) of plane to horizon.

Ordinates: = Horizontal pressure (R) in grammes.

○ Represents points observed.

× Represents points given by equation, $R = \text{weight} \times \text{tangent } \alpha$.

pressure for a zero angle of inclination. This, of course, must be the case for a plane of no thickness, and cannot be true for any planes of finite thickness with square edges, though it may be and is sensibly so with those whose edges are rounded to a so-called "fair" form. Now, the actual planes of the experiments presented a squarely-cut end-surface one-eighth of an inch ($3^{mm}.2$) thick, and for low angles of inclination this end-surface is practically normal to the wind. Both the computed pressures for such an area and the actually measured pressures, when the plane is set at 0, indicate conclusively that a large portion of the pressures measured at the soaring speeds of 2° , 3° , and 5° is *end* pressure, and if this be deducted, the remaining pressure agrees well with the position of the curve. The observed pressures, therefore, when these features are understood, become quite consistent. The curve represents the result obtained from these observations for the horizontal pressure on a plane with "*fair*"-shaped edges at soaring speeds.

A comparison of this experimental result can now be made with the formula, which appears to be nothing else than an expression for a simple resolution of forces. I say "appears," since error is so subtle in its intrusion in these cases that I have preferred to give the matter, even here, experimental confirmation.

From the analysis above given we have the equation $R = W \tan \alpha$, * W being the vertical component of pressure which, at the instant of soaring, is the weight of the plane. For the purpose of comparing the points given by this equation with the curve deduced from the observed pressures, the former are shown by crosses on the diagram with the curve. The agreement between the two is remarkably close, and, according to the standpoint from which the subject is viewed, we may say that the formula is actually identifiable, as it appears to be, with a simple case of the resolution of forces, or that the accuracy of the harmonized experiments is established by their accordance with an unquestioned law of mechanics.

WORK NECESSARY TO BE EXPENDED IN FLIGHT.

Having now obtained final values for the horizontal pressure, or the resistance to the horizontal advance of inclined planes, and having determined their soaring speeds at different angles of inclination, the work necessary to be expended per minute in propelling such planes through the air is given in kilogrammeters by the expression $60RV$, R being the horizontal pressure in grammes, and V the soaring speed expressed in meters per second.

The following table, XIII, contains a computation, for the case of the 30×4.8 inch plane weighing 500 grammes, of the work necessary to be expended per minute, the values of R being taken from the curve of figure 11:

**Note to Second Edition.* According to what has been said, this is only true for different angles of the same plane under the same aspect. (See p. 60.)

TABLE XIII.

Angle with horizon α .	Soaring speed V .		Horizontal pressure R .	Work expended per minute $60RV$.		Weight with planes of like form that 1 horse-power will drive through the air at velocity V .		[Note to second edition.] $R=W \tan \alpha$ R .
	Meters per second.	Feet per second.	(Observed.) Grammes.	Kilogram-meters.	Foot-pounds.	Kilo-grammes.	Pounds.	(Calculated.) Grammes.
45°	11.2	36.7	500	336	2,434	6.8	15	500.
30	10.6	34.8	275	175	1,268	13.0	29	288.
15	11.2	36.7	128	86	623	26.5	58	134.
10	12.4	40.7	88	65	474	34.8	77	88.15
5	15.2	49.8	45	41	297	55.5	122	43.75
2	20.0	65.6	20	24	174	95.0	209	17.5

This table shows that for an inclination of 2° the velocity of flight which suffices for soaring is 20.0 meters per second, and that the work expended per minute to support the plane (weighing 500 grammes) is 24 kilogrammeters, or 174 foot-pounds. The 7th and 8th columns contain the weight with planes of like form that one horse-power will drive through the air at velocity V . At 2° this is 95 kilogrammes, or 209 pounds. This, strictly speaking, holds good only for a system of planes whose weight, inclusive of any actual motor or other attached weight, is 500 grammes per square foot of inclined plane surface, and which is made up of 30 x 4.8 inch planes. The experiments with the *Plane-Dropper* show that in horizontal flight at attainable speeds, a system of such planes can be made by placing one above the other at a distance of about 4 inches without any sensible diminution of relative efficiency. Whether these relations of power, area, weight, and speed, experimentally established for small planes, will hold good in the same ratios for indefinitely large ones, I am not prepared to say; but from all the circumstances of experiment, I can entertain no doubt that they do so hold, far enough to afford entire assurance that we can thus transport (with fuel for a considerable journey) weights many times greater than that of a man.

The preceding investigation, which results in an expression for the varying amounts of work done by an elementary aerodrome driven at the various soaring speeds corresponding to the various angles given, has been derived for the case in which the direction of propulsion of the aerostat is horizontal and in which its plane makes an angle α with the horizon. In the case of an actual aerodrome, however, it will very probably be found advantageous to propel it in the line of its plane at such an angle (in practice a very small angle) that the resultant forward motion due to this elevation and to the simultaneous action of gravity will be exactly horizontal. If in this case its horizontal velocity be represented by V , the work done per unit of time will be expressed by the product of the

weight multiplied by $V \tan \alpha$, the latter factor being the height H to which the plane is virtually lifted against gravity.

It will be seen, now, that this expression is the same as that derived for the former case, V being the horizontal forward velocity, and α the inclination of the plane to the horizon. In order to prove the perfect identity of significance of the two expressions it, would, however, remain to show experimentally that the relation of V to α in this new case is the same as that experimentally derived for the first case. I have made no experiments with which to determine this relation, but I may say that, since all the circumstances of the resulting motion seem the same in the one case as in the other, the relation between V and α is presumably the same, and consequently the amount of work done in the second case is presumably the same as that done in the first case; it is certainly so nearly so that whenever α is small (and it always is so in such economic or horizontal flight), we may, for all practical purposes, assume an identity of the two cases. It follows that, in soaring with (horizontal) velocity V , the direction of propulsion can vary between 0° and α° at will, without sensibly changing the amount of work that is expended, so long as the plane remains at the angle α with the horizon.

The reader who has followed the description of this instrument will see that the experiments have consisted in measuring with a dynamometer the actual resistance to motion experienced by planes when just "soaring" or supporting themselves under all the circumstances of flight in free air, except that the plane is restricted from the "flouncing" caused by irregular currents, etc., and made to hold a steady flight.

The most important conclusion may be said to be the confirmation of the statement that *to maintain such planes in horizontal flight at high speeds, less power is needed than for low ones.*

In this connection I may state the fact, surely of extreme interest in its bearing on the possibility of mechanical flight, that while an engine developing one horse-power can, as has been shown, transport over 200 pounds at the rate of 20 meters per second (45 miles an hour), such an engine (*i. e.*, engine and boiler) can be actually built to weigh less than one-tenth of this amount.

Experiments with the Component Pressure Recorder to measure the horizontal pressure on normal and inclined planes and to determine their soaring speeds.

TABLE XIV—FIRST SERIES.

F. W. VERY, *Conducting experiments*; JOSEPH LUDEWIG, *Regulating engine.*

Date.	Mean barometer (millimeters).	Mean temperature (centigrade).	Mean wind velocity (meters per second).
1890. September 29.....	741.0	14°	0.30
October 1.....	738.6	17	1.20
“ 2.....	736.6	18	0.50
“ 3.....	735.8	15	0.55
“ 4.....	734.5	19	0.60
“ 7.....	727.7	15	0.60
“ 8.....	736.6	15	0.30
“ 9.....	740.1	17	0.50

Date.	Description of planes.	Angle of elevation α .	Attitude of plane.	Velocity of center of plane V (meters per second).	Number of spring.	Extension of spring (inches).	Pull of spring (grammes).	Horizontal pressure on plane R (gram's).	k_m .	k .
1890. Sept. 29	24 x 6 inches (61.0 x 15.2) Weight, 500 grammes.	30°	12.0	4	1.20	708	371		
“		15	Soaring.....	12.2	4	0.30	294	154		
“		10	“.....	13.6	4	0.20	229	120		
Oct. 1	24 x 6 inches (61.0 x 15.2) Weight, 250 grammes.	90	9.6	4	2.80	1,358	712	.0083	.00158
“		30	Soaring.....	7.8	4					
“		30	“.....	7.8	2	1.31	294	154		
“		15	“.....	8.3	“	0.64	164	86		
Oct. 2		30	“.....	7.9	“	1.25	284	149		
“		15	“.....	8.0	“					
“		10	“.....	8.6	“	0.50	134	70		
“		5	“.....	11.8	“	0.45	121	63		
“		3	Not quite soaring	13.3	“	0.35	101	53		
“		3	Soaring.....	15.4	“	0.39	107	56		
“		2	“.....	17.6	“	0.41	113	59		
“		0	Not soaring.....	25.0	“	0.50	134	70		
Oct. 3	24 x 6 inches (61.0 x 15.2) Weight, 1,000 grammes.	90	6.7	4	0.88	567	297	.0071	.00135
“		90	7.2	“	1.21	708	371	.0077	.00146
“		90	9.8	“	2.80	1,358	712	.0079	.00151
“		30	Soaring.....	15.2	“	1.60	867	454		
“		15	“.....	16.2	“	0.95	594	311		
“		10	“.....	19.4	“	0.68	480	252		
“		5	Not soaring.....	25.0	“	0.50	397	208		

TABLE XIV—Continued.

Date.	Description of planes.	Angle of elevation α .	Attitude of plane.	Velocity of center of plane V (meters per second).	Number of spring.	Extension of spring (inches).	Pull of spring (grammes).	Horizontal pressure on plane R (gram's).	k_m .	k .
1890.										
Oct. 3	12 x 12 inches (30.5 x 30.5) Weight, 500 grammes.	30	9.5	4	2.70	1,325	694	.0083	.00157
"		90	8.3	"	1.84	970	508	.0079	.00150
"		30	Soaring.....	9.5	"	0.75	510	267		
"		15	".....	12.0	"	0.27	271	142		
"		10	".....	15.0	"	0.12	159	83		
"		10	".....	14.6	2	0.80	197	103		
"		5	".....	20.0	"	0.70	176	92		
"	12 x 12 inches (30.5 x 30.5) Weight, 250 grammes.	90	6.2	"	2.20	471	247	.0069	.00132
"		30	Soaring.....	6.6	"	1.02	242	127		
"		15	".....	9.1	"	0.49	130	68		
"		10	".....	10.6	"	0.45	120	63		
"		5	".....	14.6	"	0.35	100	52		
"		3	".....	16.7	"	0.40	113	59		
"		2	".....	18.8	"	0.55	145	76		
"		0	Not soaring....	23.1	"	0.80	199	104		
Oct. 4	12 x 12 inches (30.5 x 30.5) Weight, 1,000 grammes.	90	7.0	4	1.25	726	380	.0084	.00160
"		90	9.4	"	2.48	1,235	647	.0079	.00150
"		30	Soaring.....	12.8	"	1.85	970	508		
"		30	".....	12.8	"	1.80	953	499		
"		15	".....	17.4	"	0.57	435	228		
Oct. 3		15	".....	16.7	2	1.75	388	203		
"		10	".....	20.0	"	1.25	285	149		
"		5	".....	25.5	"	0.80	199	104		
Oct. 7	6 x 24 inches (15.2 x 61.0) Weight, 250 grammes.	90	6.2	"	2.65	563	295	.0081	.00155
"		30	Soaring.....	7.6	"	1.35	308	161		
"		15	".....	11.8	"	0.90	216	113		
"		10	".....	14.1	"	0.60	155	81		
"		5	".....	21.1	"	0.90	216	113		
"		3	Nearly soaring..	25.0	"	1.00	235	123		
"	6 x 24 inches (15.2 x 61.0) Weight, 500 grammes.	90	6.3	"	2.70*	571*	299*	.0081*	.00154*
"		90	5.4	"	2.08	453	237	.0089	.00169
"		90	4.1	"	1.10	256	134	.0085	.00161
"		30	Soaring.....	10.5	"	2.30	492	258		
"		15	".....	15.2	"	1.00	235	123		
"		10	".....	20.7	"	0.85	206	108		
"		5	".....	27.3	"	0.65	166	87		
"	6 x 24 inches (15.2 x 61.0) Weight, 1,000 grammes.	90	7.3	4	1.70	909	476	.0096	.00182
"		90	5.7	"	0.95	597	313	.0103	.00197
"		30	Soaring.....	14.6	"	1.80	953	499		
"		15	".....	21.4	"	0.60	450	236		
"		10	".....	27.3	"	0.30	294	154		

*Trace was at limit of admissible extension, and hence the correct results are greater than these values.

TABLE XIV—Continued.

Date.	Description of planes.	Angle of elevation α .	Attitude of plane.	Velocity of center of plane V (meters per second).	Number of spring.	Extension of spring (inches).	Pull of spring (grammes).	Horizontal pressure on plane P (gram's).	k_m .	k .
1890.										
Oct. 8	6 x 24 inches (15.2 x 61.0) Weight, 1,000 grammes.	15	Soaring.....	21.8	2					
"		10	".....	28.6	"					
"		5	Not soaring.....	30.0	"	0.40	113	59		
"	30 x 4.8 inches (76.2 x 12.2) Weight, 500 grammes.	90	5.0	"	1.40	317	166	.0073	.00138
"		90	6.0	"	2.20	471	247	.0075	.00142
"		90	6.2	"	2.45	527	276	.0076	.00145
"		30	Soaring.....	10.6	"	2.30	492	258		
"		10	".....	17.9	"	0.75	183	96		
"		10	".....	12.1	"	0.90	216	113		
"		5	15.2	"	0.45	122	64		
"		3	Not soaring.....	21.1	"	0.50	134	70		
"		0	25.0	"	0.90	216	113		
"	30 x 4.8 inches (76.2 x 12.2) Weight, 250 grammes.	90	5.8	"	2.60	554	290	.0091	.00173
"		90	4.3	"	1.20	277	145	.0086	.00163
"		30	Soaring.....	8.1	"	1.30	294	154		
"		15	".....	8.3	"	0.50	134	70		
"		10	".....	9.3	"	0.35	100	52		
"		5	".....	13.3	"	0.40	113	59		
"		3	".....	17.1	"	0.55	145	76		
"		2	26.1	"	0.50	134	70		
"		2	22.2	"	1.20	277	145		
"		0	27.9	"	1.50	336	176		
Oct. 9	30 x 4.8 inches (76.2 x 12.2) Weight, 1,000 grammes.	90	5.8	4	0.7	490	257	.0082	.00157
"		90	8.3	"	1.7	909	476	.0074	.00141
"		30	Soaring.....	15.2	"	2.2	1110	581		
"		15	".....	17.1	"	1.1	659	345		
"		15	".....	17.4	2	2.3	492	258		
"		10	".....	17.9	4					
"		10	".....	18.2	2	1.9	416	218		
"		5	".....	22.6	"	1.6	355	186		

Average of 22 determinations of k_m (at mean temperature, 16° C.) = .00816.

TABLE XV—SECOND SERIES.

NOVEMBER 25, 1890.—F. W. VERY, *Conductor of experiments.*

Barometer, 730 mm.; temperature, 10°.0 C.; wind velocity, 2.4 meters per second.

Description of planes.	Angle of elevation α .	Attitude of plane.	Velocity of center of plane V (meters per second).	Number of spring.	Extension of spring (inches).	Pull of spring (grammes).	Horizontal pressure on plane R (gram's).	Remarks.
24 x 6 in. (24 in. side horizontal). Weight, 500 grammes.	45°	Soaring.....	10.9	4	2.10	907	476	Adopt 19.6 for soaring speed. Too small extension of spring to give reliable pressure.
	50	"	11.2	4	2.50	1,070	560	
	5	"	16.9	4				
	5	"	17.2	3	0.38	82	43	
	3	Not quite soaring	19.4	
	30	Soaring.....	10.6	4	1.10	499	261	
	10	"	13.3	4	0.21	91	48	

NOVEMBER 26, 1890.—F. W. VERY, *Conductor of experiments.*

Barometer, 736 mm.; temperature, 0°.0 C.; wind velocity, 0.3 meters per second.

Description of planes.	Angle of elevation α .	Attitude of plane.	Velocity of center of plane V (meters per second).	Number of spring.	Extension of spring (inches).	Pull of spring (grammes).	Horizontal pressure on plane R (gram's).	k_m .	k .	Remarks.
24 x 6 in. (24 in. side horizontal). Weight, 500 grammes.	0°	16.6	3	0.10	27	14			
	2	18.3	3	0.40	82	43			
	3	Soaring...	16.2	3	0.45	86	45			
	5	"	14.4	3	0.57	100	52			
	90	9.03	4	2.50	1,068	558	.0074	.00141	
	90	7.41	4	1.70	749	392	.0077	.00146	
Same plane (6 in. side horizontal).	90	7.99	4	1.85	803	421	.0071	.00136	
	90	5.86	4	0.97	454	238	.0075	.00142	
6 x 6 inches. Weight, 125 grammes.	90	17.96	4	2.40	1,021	534	.0071	.00136	
	90	16.74	4	2.05	885	464	.0071	.00136	
	3	Soaring...	20.1	3	0.50	91	48			
	5	"	18.7	3	0.60	100	52			
	10	"	15.0	3	0.73	113	59			

TABLE XV—Continued.

Description of planes.	Angle of elevation α .	Attitude of plane.	Velocity of center of plane V (meters per second).	Number of spring.	Extension of spring (inches).	Pull of spring (grammes).	Horizontal pressure on plane R (gram's).	k_m .	k .	Remarks.
12 x 12 inches. Weight, 500 grammes.	0	16.7	3	0.35	77	40			
	0	17.8	3	0.40	84	44			
	2	} Not soaring.	20.7	3	0.70	109	57			
	2		16.7	3	0.55	95	50			
	3	Nearly soaring.	20.9	3	1.00	131	69	Adopt 21.4 m. per sec. as probable soaring speed.
	5	Soaring...	20.1	3	1.30	152	80			
	10	" ...	15.8	3	1.70	180	94			
	20	" ...	11.1	3	Spring extended to limit.
	20	" ...	11.1	4	0.75	340	178			
	30	" ...	8.9	4	1.20	345	285			
	45	" ...	10.2	4	2.31	985	516			
	90	8.23	4	2.20	939	492	.0078	.00148	
	90	8.45	4	2.28	976	511	.0077	.00146	
	90	9.15	4	2.70	1,135	595	.0077	.00146	
90	8.11	4	2.00	863	452	.0074	.00141		
12 x 6 in. (12 in. side horizontal). Weight, 250 grammes.	0	18.6	3	0.55	95	50			
	3	Scarcely soaring.	18.8	3	0.67	107	56	Probable soaring speed, 19.2 m. per sec.
	5	Soaring...	17.5	3	0.78	115	60			
	10	" ...	13.3	3	1.00	131	69			
	20	" ...	10.8	3	1.75	182	95			
	20	" ...	11.0	4	0.33	159	83			
	30	" ...	10.5	4	0.77	347	182			
	45	" ...	10.9	4	1.14	522	273			
	90	7.78	4	0.83	399	209	.0074	.00141	
	90	9.09	4	1.21	549	288	.0075	.00142	
	90	10.89	4	1.98	862	452	.0082	.00156	
	90	12.50	4	2.55	1,089	571	.0079	.00150	
	90	11.19	4	2.02	871	456	.0079	.00149	
	90	10.00	4	1.60	704	369	.0079	.00151	
90	8.14	4	1.00	463	243	.0079	.00150		
30 x 4.8 in. (30 in. side horizontal). Weight, 500 grammes.	0	17.9	3	0.30	72	38			
	2	Soaring...	20.1	3	0.90	125	65			
	3	" ...	17.8	3	1.04	134	70			
	5	" ...	15.2	3	1.12	138	72			
	10	" ...	12.6	3	1.92	197	103			
	20	11.7	3	3.34	300	157			
	20	11.6	4	0.70	295	155			
	30	Soaring...	10.8	4	1.21	550	288			
	45	" ...	11.2	4	2.12	912	478			
	90	8.39	4	2.20	935	490	.0075	.00143	
	90	10.26	4	3.30	1,380	723	.0074	.00141	
	90	8.00	4	2.05	885	464	.0078	.00148	

TABLE XV—Continued.

DECEMBER 5, 1890.—F. W. VERY, *Conductor of experiments.*

Barometer, 732 mm.; temperature, + 1°.0 C.; wind velocity, light.

Description of plane.	Angle of elevation α .	Attitude of plane.	Velocity of center of plane V (meters per second).	Number of spring.	Extension of spring (inches).	Pull of spring (grammes).	Horizontal pressure on plane R (gram's).	Remarks.
12 x 12 inches. Weight, 500 grammes.	10°	More than soaring.	15.8	3	1.80	191	100	
	10	Soaring	15.0					

Flange of cone-pulley broke and stopped observations for the day.

DECEMBER 6, 1890.

Barometer, 730 mm.; temperature, + 2°.5 C.; wind velocity, calm.

Description of planes.	Angle of elevation α .	Attitude of plane.	Velocity of center of plane V (meters per second).	Number of spring.	Extension of spring (inches).	Pull of spring (grammes).	Horizontal pressure on plane R (gram's).	Remarks.
12 x 12 inches. Weight, 500 grammes.	20°	Soaring	12.8	3	2.60	245	128	Velocity of soaring not so well determined as on November 26.
	20	"	12.6	4	Velocity of soaring not so well determined as on November 26.
	30	"	10.3	4	1.10	500	262	Velocity of soaring not so accurately determined as on November 26.
	45	"	11.4	4	2.20	939	492	Velocity of soaring not so accurately determined as on November 26.
	45	Not soaring.....	10.0	4	1.82	794	416	Velocity of soaring not so accurately determined as on November 26.
	30	" "	10.0	4	0.85	408	214	Velocity of soaring not so accurately determined as on November 26.
	30	" "	10.0	4	0.75	340	178	Velocity of soaring not so accurately determined as on November 26.
30 x 4.8 inches. Weight, 500 grammes.	20	" "	10.0	3	1.00	131	69	Velocity of soaring not so accurately determined as on November 26.
	5	Not quite soaring.	14.3	14.9 meters per second assumed as soaring speed.

Fine mist throughout the observations.

TABLE XV—Continued.

DECEMBER 11, 1890.—F. W. VERY, *Conductor of experiments.*

Barometer, 724 mm.; temperature, + 5° C.; wind velocity, 0.8 meters per second.

Description of planes.	Angle of elevation α .	Attitude of plane.	Velocity of center of plane V (meters per second).	Number of spring.	Extension of spring (inches).	Pull of spring (grammes).	Horizontal pressure on plane R (gram's).	k_m .	k .	Remarks.
30 x 4.8 in. (30 in. side horizontal). Weight, 500 grammes.	90°	8.30	1	1.80	930	487	.0076	0.00144	
	90	9.15	1	2.20	1,098	576	.0074	0.00140	
	45	Soaring....	11.3	1	2.10	1,057	553			
	30	"	1	0.91	557	292			
	20	"	10.9	1	0.47	350	183			
	15	"	11.1	3						
24 x 6 in. (24 in. side horizontal). Weight, 500 grammes.	0	20.7	3	0.20	59	31			
	10	Soaring....	13.0							

Mean of 22 determinations of k_m (at temperature 0° C.) = 0.0076.

CHAPTER VII.

THE DYNAMOMETER-CHRONOGRAPH.

Having determined by means of the *Component-Recorder* the resistance that must be overcome in moving a material plane horizontally through the air at different speeds, the next step of my investigation has consisted in devising means for measuring the power that must be put out by a motor in doing this useful work; for, by any form of aerial propulsion, the useful work that can be derived from the motor is only a percentage, either large or small, of that which is expended. It becomes important, therefore, to determine the ratio between the propelling force obtained, and the amount of power that must be expended in any given case.

In devising the following apparatus I have confined my attention to aerial propellers for reasons of present convenience, and not because I think them the only practicable method of propulsion, although they are undoubtedly a most important one.

If we consider the actual circumstances of such experiments, where the motor under investigation is mounted at the extremity of the large turn-table arm and is in motion, frequently at a rate of over a mile a minute, and that the end of this slender arm is 30 feet from any solid support where an observer might be stationed, it will be seen that the need of noting at every moment the action of apparatus, which under such circumstances is inaccessible, imposes a difficult mechanical problem. After trying and dismissing other plans, it became evident that a purely automatic registry must be devised which would do nearly all that could be supposed to be done in the actually impracticable case of an observer who should be stationed at the outer end of the whirling arm beside the apparatus, which we may suppose for illustration to be an aerodrome moved by a propeller. The registering instrument for the purposes desired must indicate at every moment both the power expended on the supposed aerodrome to make it sustain itself in flight, and also the portion of that power which is utilized in end-thrust on the propeller shaft, driving the model forward at such a rate as to maintain soaring flight, under the same circumstances as if it were relieved from all constraint and actually flying free in a horizontal course in the air. For this purpose a peculiar kind of dynamometer had to be devised, which, after much labor over mechanical difficulties, finally became completely efficient in the form

I proceed to describe and which I have called the *Dynamometer-Chronograph*. A plan of the instrument is given in plate VIII. Its method of operation in measuring and registering (1) the power expended in producing rotation and (2) the useful result obtained in end-thrust is here separately described.

(1) MEASUREMENT OF THE POWER EXPENDED.

The propeller wheel L, which is to be investigated, is fastened to the shaft SS', which becomes its axis, and is driven by a belt running from the pulley.

When the pulley is driven from any source of power, the resistance offered by the air to the rotation of the propeller develops a torsional force on the shaft SS'. This shaft is divided into two portions at the clock-spring in the upper end of the cylinder D, so that the torsional force set up by the pulley is transmitted to the rest of the axis and to the propeller through the spring in question. This torsional force can and does cause the cylinder E, which turns with the propeller end of the shaft, to be twisted with respect to D, which rotates with the pulley, until the force is balanced by the winding tension of the clock-spring. The relative angular motion between the pulley and the shaft S causes a longitudinal motion of the cylinder E into the cylinder D, by means of a spiral groove cut in the cylinder D, in a manner which is sufficiently shown in the drawing, so that there can be no angular movement of the pulley C relative to the shaft and to the cylinder E, without a corresponding longitudinal motion of the cylinder E and of the pencil P", which registers the amount of this longitudinal motion on the recording cylinder; and it will be observed that there will be no angular motion and no linear motion, unless *work* is being done by the pulley; for, if the propeller wheel were removed, or if its blades were set with their planes in the planes of its rotation, however fast the pulley may be driven, there will be no record. The linear motion of the pen P" is, then, caused by, and is proportional to, the torsional force exerted by the pulley, and to this only. It is obvious that if the recording cylinder revolve at a known rate, the pencil trace will give a complete record of the two necessary and sufficient factors in estimating the total power put out, namely, the amount of this power from instant to instant (however it vary) and the time during which it is exerted; the former being given by the "departure" of the pen from its normal position, the latter by the length of the trace, so that a complete *indicator-diagram* showing the power expended is found on the sheet when it is unrolled from the cylinder. The abscissa of any point in the developed curve is proportional to the time; its ordinate, which represents the departure of the pencil parallel to the axis of the cylinder, is proportional to the tension of the clock-spring. The value of this departure, or the actual stress it represents, after allowing for all circumstances of friction, is obtained by calibrating the spring by hanging weights on the circumference of

the pulley. This departure, then, corresponds to the effect of a definite and constant weight so applied, so long as we use the same spring under the same adjustment. When widely different ranges of power are to be measured, the additional range of tension required is obtained with the same spring by inserting a set-screw in successive holes, numbered 0 to 15, around the end of the cylinder D, so as virtually to shorten or lengthen the clock-spring. A separate calibration is, of course, required for each setting.

(2) MEASUREMENT OF THE END-THRUST.

I have thus far spoken of the shaft or axis as if it were in one piece between the clock-spring and the pulley, but for the purpose of measuring the *end-thrust* the shaft is also cut in two within the cylinder F. The two pieces are maintained in line by suitable guides, and forced to *rotate* together by a fork within F, but the propeller end of the shaft is given freedom of longitudinal motion. Any end-thrust on the axis, whether received from the propeller or otherwise, causes, then, this portion carrying the pencil P to slide up within the other toward the pulley, telescoping the part of the shaft next the propeller within that next the clock-spring, and causing the longitudinal compression of the spiral spring in cylinder F, as shown in the drawing. All the parts of the axis, then, between the clock-spring and the propeller must rotate together when the latter is revolved, but the end of the axis nearest the propeller, and this end only, has the capacity not only of rotatory but of a longitudinal motion, which latter is permitted by this portion of the axis telescoping into the other, as above described. The force of the end-thrust is recorded by the "departure" of the pencil P, which bears a definite relation to its own spring, determined by independent calibration. The record made by P on the recording cylinder is a curve whose abscissæ are proportional to time and whose ordinates are proportional to end-thrust. This curve cannot by itself properly be called an indicator-diagram, since, taken alone, it records a static pressure only, but when the experiments are adjusted in a manner later described in this chapter the record of the speed of the turntable (on which it will be remembered this apparatus is being carried forward) supplies the requisite additional data that an indicator-diagram demands. Hence, while the pencil P' actually traces an indicator-diagram giving the expenditure of power at every moment, the pencil P traces in part a second indicator-diagram giving synchronously the useful result attained.

A third pencil, P', records the seconds of a mean time-clock through the action of an electro-magnet, M, and obviously gives the means of determining with all needful precision the time corresponding to each element of angular rotation of the cylinder, even should this vary. This time record, then, serves two purposes: (1) it gives the speed of rotation of the cylinder, and (2) permits

the traces to be synchronized with the speed of the whirling table registered on the stationary chronograph.

The cylinder is rotated in either of two ways: (first) by the driving pulley, through a system of gearing, which gives the cylinder rates of rotation equal to $\frac{1}{4000}$, $\frac{1}{2000}$, or $\frac{1}{1000}$ that of the driving pulley according as desired, so that the speed of the pulley is thus measured by the rate of rotation of the cylinder; or (second) the cylinder may be independently rotated by an attached clock when it is desired to give it a uniform motion rather than to record the speed of the pulleys. In practice the clock and recording cylinder have been used as the registering apparatus in most of the experiments already described with other instruments.

The drawing shows a portion of an actual dynamometer trace which was obtained with the instrument when set in motion by a foot-lathe, the power supplied by the foot through the fly-wheel of the lathe being transferred by a belt to the pulley and thence to a propeller wheel carried at the end of the shaft S. The pencil P", it will be remembered, is connected with the clock-spring, its "departure," or motion parallel to the axis, being in this case at every instant proportional to the tension at the same instant at the circumference of the pulley. P' is the pencil, which records every beat of the mean time-clock, while the trace made by the third pencil, P (in the case actually under consideration, in which the dynamometer is at rest), measures the static end-thrust obtained from the propeller blades for the amount of power put out. I may ask attention to the comparability of these two absolutely independent traces, and invite the reader to note how perfectly the relation of end-thrust obtained responds to the power expended. The person turning the lathe did so with the greatest uniformity attainable by the use of a heavy fly-wheel, but every motion of the foot is, nevertheless, as will be seen, most conspicuously registered. Every change in the amount of power finds also its counterpart in a variation of end-thrust, and the inequalities in the application of the power during a single revolution of the fly-wheel of the lathe may be distinctly traced not only in the first of the two curves but in the second. (It is interesting to note that in each stroke the power pen P" starts up sharply and then comes nearly or quite back to the zero line, although we see from the pen P that work is being done all the time. This is repeated substantially at every stroke of the foot, in spite of the inertia of the lathe fly-wheel, and is an indication of the extreme sensitiveness of the apparatus.)

Preliminary to the use of the dynamometer it was necessary, as has been explained, to calibrate the clock-spring and the end-thrust spring and prepare curves or tables for evaluating the readings of the traces.

The clock-spring was calibrated in the following manner: The propeller end of the axle being held fast, weights were applied at the circumference of the large pulley, 10 centimeters diameter, by means of a cord. The torsional force

of these weights at a lever-arm of 5 centimeters (the effective radius of the pulley) is balanced by the tension of the clock-spring and is measured by the longitudinal motion of the pencil P". On account of the appreciable friction of the guide-wheel in the helical groove, two measures are desirable for exact calibration in each case at an upper and lower limit of repose. The mean of these is taken as the true extension for the given weight, and the observation is repeated three times with each weight to eliminate errors of observation. This series of observations was made with the set-screw in the "0" hole, the 5th hole, and the 10th hole, in order to get a sufficiently wide range of action for the instrument

The following table, XVI, gives the system of calibration obtained from experiments made November 14, 1890—F. W. Very, observer :

TABLE XVI.

Calibration of Clock-Spring of Dynamometer.

Weight applied at circumference of large pulley, effective radius 5 centimeters, by cord passing over a small pulley at edge of table.

Position of set-screw.	Weight.		Extension of trace.	
	Pounds.	Grammes.	Inches.	Centimeters.
10th hole.....	4.32	1,960	1.84	4.67
	4.10	1,860	1.70	4.32
	3.88	1,760	1.49	3.77
	3.44	1,560	1.02	2.59
	3.22	1,460	0.86	2.18
	3.00	1,360	0.60	1.52
	2.78	1,260	0.37	0.94
5th hole.....	3.00	1,360	1.82	4.62
	2.78	1,260	1.60	4.06
	2.56	1,160	1.35	3.43
	2.34	1,060	1.15	2.92
	2.12	960	0.88	2.24
	1.90	860	0.66	1.68
	1.68	760	0.41	1.04
"0" hole.....	1.83	830	1.86	4.73
	1.61	730	1.64	4.17
	1.30	630	1.39	3.53
	1.17	530	1.18	3.01
	0.95	430	0.91	2.31
	0.73	330	0.71	1.79
	0.51	230	0.49	1.24
	0.29	130	0.25	0.63
	0.07	30	0.15	0.38

The end-thrust spring was calibrated by suspension of weights in a similar way. The following calibration was obtained from experiments made March 8, 1888:

Calibration of End-Thrust Spring.

Weight.	Extension of trace.
(Grammes).	(Centimeters).
100	0.43
200	1.07
300	1.75
400	2.21

The method of computing the horse-power expended, and the return in end-thrust obtained, may now be illustrated in the reduction of the following observations taken without change from the original notes:

OCTOBER 30, 1888.

Six-bladed propeller, with blades set at 45° with axis. *Dynamometer* driven by belt from a small dynamo. Belt driving 2.1 inch pulley. *Dynamometer* geared so as to give one revolution of cylinder for 2,000 revolutions of pulley. Time of one revolution of cylinder, 295 seconds. Departure of pencil of clock-spring (set-screw in "0" hole), 1.43 inches.

Driving pulley makes $\frac{60 \times 2000}{295}$ revolutions per minute. Circumference of pulley equals $\frac{2.1 \times 3.1416}{12}$ feet. Velocity of belt equals $\frac{60 \times 2000 \times 2.1 \times 3.1416}{295 \times 12}$ feet per minute. From calibration of March 8, 1888, an extension or departure of 1.43 inches of the pencil of the clock-spring, with the set-screw in "0" hole, is equivalent to a weight of 1.35 pounds on a 3.9-inch pulley. The tension on the present 2.1-inch driving pulley is therefore $1.35 \times \frac{3.9}{2.1}$ pounds. Multiplying tension of belt by velocity of belt and dividing by 33,000, we have the work expended per minute expressed in horse-power, viz:

$$\frac{60 \times 2000}{295 \times 12} \times 3.1416 \times \frac{1.35 \times 3.9}{33000} = 3.713 \times \frac{1.35}{295} = 0.017.$$

It will be noticed that in this expression the factor 2.1 has dropped out, and the only variables are the time of one revolution of cylinder and the tension on the spiral spring taken from the calibration curve. If the former be represented by a and the latter by b , and the gearing remain unchanged, the horse-power in any experiment will be given by the formula $3.713 \times \frac{b}{a}$.

I have now to ask attention to a condition of vital importance in the experiments, and yet one which may, perhaps, not appear obvious. It is, that it is indispensable that the power expended on, and obtained from, the propeller shall, for its economical use, be expended on fresh and undisturbed masses of air. To make my meaning clearer, I will suppose that the *Dynamometer-Chronograph* is mounted on a fixed support in the open air, with the axis pointing east and west, and that in a perfect calm a certain amount of power (let us suppose n horse-power) is put out on a pulley and through it on the propeller, giving a certain return in end-thrust. Under these circumstances, let the wind blow either from north to south or from south to north; that is, directly at right angles with the axle, so that it might at first sight appear that nothing is done to increase or diminish the amount of end-thrust to be obtained. The amount of end-thrust under these circumstances will, in fact, be very greatly increased (even though the constant expenditure of n horse-power be maintained)—so greatly increased, that a neglect of such considerations would completely vitiate the results of experiment, the great difference being due to the fact that the propeller-wheel is now operating from moment to moment on fresh masses of air whose inertia has been undisturbed.

This being understood, it is not desirable for our purpose to experiment upon the case where the air is carried at right angles or at any very considerable angle to the propeller shaft—a case which is used here only for illustration of a principle. The circumstances of actual motion cause the wind of advance to be always nearly in the line of the shaft itself; and this condition is obtained by moving the instrument so that the wind of advance caused by the motion of the turn-table is in this direction. It is this supply of fresh material (so to speak) for the propeller to work upon, which causes the need of noting minutely the speed of advance, as affecting the result, so that for a given constant quantity of power expended, the percentage of return in end-thrust depends upon the rate of supply of fresh and undisturbed masses of air. These considerations very intimately connect themselves with the theory of the marine screw-propeller, and the related questions of slip and rate of advance, but I have preferred to approach them from this somewhat less familiar point of view.

The dynamometer and propeller were therefore mounted, as has been said, on the end of the whirling-table. The propeller was driven by means of its pulley C by a belt from a small electro-motor also on the turn-table, the motor being actuated by a current from a stationary dynamo, shown on plate II. This dynamo sent a current through the brush contact B of the whirling-table to the small electric motor mounted on the arm. The whirling-table was then raised

out of its gearings by the means shown in plate II, and with full current from the dynamo the little propeller blades proved capable of rotating the great turn-table, though slowly, for manifestly the work to be done in moving this great mass was quite incommensurate with the capacity of a small propeller of 15 or 20 inches radius. Some special means must therefore be devised for utilizing the advantages given by the attainable speed, steadiness, and size of so large a whirling-table, without encountering the disadvantages of friction, resistance of the air to the exposed surface, and similar sources of difficulty. To place the propeller wheels, either actually driving inclined planes or models, or otherwise, so far as possible under the conditions they would have in actual free flight, and to measure the power put out in actuating them, the resistance experienced, etc., under these conditions, is evidently an object to be sought, but it is equally evident that it is difficult of attainment in practice. Much study and much experiment were given to this part of the problem, with the result of the invention, or rather the gradual evolution through successive forms, of the auxiliary instrument described in the last chapter as the *Component Pressure Recorder*. This conception of a method by which the *Dynamometer* could be effectively used was reached in February, 1889, and, together with its final mechanical embodiment, was the outcome of much more thought than the invention of the *Dynamometer* itself.

As already stated, one of the objects of the *Dynamometer* is to determine the power necessary to be expended in mechanical flight; but manifestly this must be done indirectly, for we have to experiment with a model or an inclined plane so small as to be incapable of soaring while supporting the relatively great weight of the *Dynamometer-Chronograph*, even if it had an internal source of power capable of giving independent flight (which the simple inclined plane has not). If such a working model were placed upon the end of the turn-table arm, with the *Dynamometer* supported on this arm behind or beneath it, and if the arm of the turn-table were without inertia and offered no resistance to the air, the whole might be driven forward by the reaction of the propeller of the model, actuated by a motor, until the latter actually soars, and the *Dynamometer* supported on such an imaginary arm might note the work done when the soaring takes place. This conception is, of course, impossible of realization, but it suggests a method by which the actual massive turn-table can be used so as to accomplish the same result. Suppose the model with attached propeller and *Dynamometer* to be placed on the end of the whirling arm, and the latter rotated by its engine. Further, suppose the model aerodrome be also independently driven forward by its propeller, actuated by an independent motor, at the same speed as that of the table; then, if both speeds are gradually increased until actual soaring takes place, it is

evident that we reach the desired result of correct dynamometric measures taken under all the essential circumstances of free flight, for in this case the propeller is driving the model independently of any help from the turn-table, which latter serves its purpose in carrying the attached *Dynamometer*.

As a means of determining when the propeller is driving the model at a speed just equal to that of the turn-table, let the whole apparatus on the end of the arm be placed on a car which rolls on a nearly frictionless track at right angles to the turn-table arm. Then, when the turn-table is in rotation, let the propeller of the model be driven by its motor with increasing speed until it begins to move the model forward on the track. At this moment, that is, just as the aerodrome begins to move forward relatively to the moving turn-table, it is behaving in every respect with regard to the horizontal resistance (*i. e.*, the resistance to advance), as if it were entirely free from the table, since it is not moved by it, but is actually advancing faster than it, and it is subject in this respect to no disturbing condition except the resistance of the air to the bulk of the attached *Dynamometer*. In another respect, however, it is far from being free from the table, so long as this helps to take part in the vertical resistance which should be borne wholly by the air; the aerodrome, in other words, will not be behaving in every respect as if in free air, if it rests with any weight on the track. The second necessary and sufficient condition is, then, that at the same moment that the model begins to run forward with the car it should also begin to rise from it. This condition can be directly obtained by rotating the turn-table at the soaring speed (previously determined) corresponding to any given angle of the inclined plane.

This conception of a method for attaining the manifold objects that I have outlined was not carried out in the form of the track, which, although constructed, was soon abandoned on account of the errors introduced by friction, etc., but in the *Component Recorder*, whose freedom of motion about the vertical axis provides the same opportunity for the propeller-driven model to run ahead of the turn-table as is offered by the track. This instrument, therefore, a part of whose functions have been described in the preceding chapter, has been used as a necessary auxiliary apparatus to the *Dynamometer-Chronograph*, and this is an essential part of the purpose for which it was originally devised. In naming the instrument, however, only a part of its purpose and service could be included, or of the mechanical difficulties that it surmounts indicated.

The investigation of the velocity at which an inclined plane will sustain its own weight in the air, and the determination of the end-thrust, or horizontal-resistance, that is experienced at this velocity, were made with the *Recorder* independently of the *Dynamometer*, and have been presented in detail in chapter

VI. The investigation of the power that must be expended to furnish this end-thrust, and the determination of the best form and size of propeller for the purpose, combines the use of the two instruments.

In the center of the *Recorder* is provided a place (see plate VII) for the electric motor already referred to, whose power is transmitted by a belt to the pulley of the *Dynamometer-Chronograph*, which is mounted on the end of the rigid arms. It may be observed that, in this manner of establishing the motor, the tension of the pulley, however great, in no way interferes with the freedom of motion of the arms of the *Recorder*—a very essential mechanical condition, and one not otherwise easily attainable. With the various pieces of apparatus thus disposed, and with the propeller to be tested fastened to the shaft of the *Dynamometer*, the whirling table is rotated at any desired speed. The propeller is then driven by the motor with increasing amounts of power until the forward motion of the *Recorder* arm about its vertical axis indicates that the propeller is driving the *Dynamometer* ahead at a velocity just exceeding the velocity of the whirling-table. This is the moment at which all the records admit of interpretation. The work that is being done by the propeller is that of overcoming the resistance of the air to the bulk of the *Dynamometer*, and in place of this we may substitute, in thought, the resistance that would be caused by an aerodrome of such a size as to produce the same effect. The power put out and the resistance to advance are both registered on the cylinder of the *Dynamometer*. The result realized is found by multiplying the static pressure indicated by the pencil which registers the end-thrust by the velocity of the turn-table at the moment when the propeller's independently acquired velocity is just about to exceed it. The static pressure represents the resistance overcome, and the velocity of advance gives the distance through which it is overcome per unit of time. The product therefore represents the effective work done per unit of time. If the adopted velocity of the whirling-table be the soaring velocity of an aerodrome which would have the actually observed resistance, the experiment will virtually be made under all the conditions of actual horizontal flight. In practice, the experiments were made at a series of velocities, and the results obtained—power expended and useful work done—can be interpolated for any desired speed.

Preliminary experiments were made with wooden propellers having four, six, and eight blades set at different angles with the axis. Lastly, two aluminum propellers were used having only two blades each, extending 24 and 30 inches, respectively, from tip to tip.

In order that the reader may follow the method of experiment in detail, the following description of experiments made November 4, 1890, is here given, together with abstracts from the original record of observations for that date:

NOVEMBER 4, 1890.

Continuation of experiments with 30-inch (diameter) two-bladed aluminum propeller to determine ratio of power put out to return in end-thrust obtained.

Dynamometer-Chronograph with attached propeller is placed on outer arm of the *Component-Recorder* and driven by an electric motor placed in the center of the *Recorder*. The electric motor is run by a dynamo, the current from which is carried to the heavy brush contact B (plate II) of the turn-table, and thence along the arm to the electric motor, and the dynamo itself is run by the steam-engine which drives the turn-table.

In the manner already described, the pencil P'' of the *Dynamometer-Chronograph* registers the power put out; P' registers seconds from the mean time-clock, and P registers the end-thrust of the propeller. A fourth pencil is fixed to the frame of the *Recorder* and registers on the dynamometer cylinder the forward motion of the *Recorder* arm about its vertical axis against the tension of a horizontal spring, the spring being disposed so as to be extended by the *forward* motion of the outer arm. Thus, when the propeller is driven at such a velocity as just to exceed the velocity of the turn-table, the outer arm bearing the *Dynamometer* moves forward, the horizontal spring begins to extend, and its extension is recorded on the *Dynamometer* sheet, together with the power put out, the amount of end-thrust obtained, and the time trace from the mean time-clock.

Preliminary to the experiments the surface of the inner arm of the balance was increased so that the resistance of the *Dynamometer* on the outer arm to the wind of advance should be largely counterbalanced. This was accomplished by adding a surface of 17 square inches at a distance of 4 inches (104 centimeters) from the axis of rotation.

	<i>h.</i>	<i>m.</i>	
At	2	12	Casella air-meter reads 1,779,600.
At	5	39	" " " 1,881,900.

Toward end of experiments, wind almost entirely died away.

Dynamometer-Chronograph sheet No. 3—notes and measurements:

Propeller blades set at angle of 75° with axis. Horizontal spring No. 3.

Pulley cord of *Dynamometer* running on 4-inch pulley.

Chronograph cylinder geared so as to make 1 revolution to 2,000 revolutions of propeller.

Set screw of *Dynamometer* in "0" hole.

Turn-table driven so as to give linear speed of approximately 2,000 feet per minute.

(a) Dynamo = 1,170 revolutions per minute.

(b) Propeller = $\frac{5.52 \times 2000}{10.7} = 1,032$ revolutions per minute.

(c) Extension of power pencil P'' = 0.65 inches.

(d) Extension of end-thrust pencil P = 0.20 inches (varying).

(e) Horizontal spring: no appreciable extension, except occasional jumps produced by wind.

(f) Speed of turn-table (from sheet of stationary chronograph in office) = 5.41 seconds in one revolution = 1,865 feet per minute.

The above entries, taken from the original note-book, will be readily understood in connection with the following explanations:

(a) The 1,170 revolutions of dynamo refer to the revolutions of the dynamo-electric machine, and are read off by means of a Buss-Sombart Tachometer.

(b) 5.52 is the number of inches of the *Dynamometer-Chronograph* barrel revolved in a minute, as determined by measuring the time trace. An entire revolution corresponds to the entire circumference of the barrel, 10.7 inches, and (with the gearing used in this experiment) to 2,000 revolutions of the *Dynamometer* pulley shaft.

Hence

$$\frac{5.52 \times 2000}{10.7} = 1,032$$

is the number of revolutions of the *Dynamometer* pulley per minute at the time of this experiment. The effective diameter of the pulley being 4 inches, this gives for the velocity of the cord 1,063 feet per minute.

(c) The extension of the power pencil $P'' = 0.65$ inches. From the calibration tables we find that this corresponds to a tension of 0.67 pounds on the pulley cord. The product of this tension by the pulley speed gives the power put out, viz., 712 foot-pounds per minute.

(d) The extension of the end-thrust trace, 0.20 inch, corresponds to a pressure of 0.20 pound.

(e) The horizontal spring has no appreciable extension, except as caused by puffs of wind. This indicates that the propeller is not driving quite fast enough to equal or exceed the velocity of the turn-table; but the deficiency of velocity is so small that we shall not discard the experiment, but compute the record as if the requisite velocity were just attained.

(f) The speed of turn-table multiplied by the end-thrust gives the work done per minute by propeller, viz., 373 foot-pounds per minute.

We have, then, as a result of the experiment, that the ratio of work done by the propeller to the power put out is 52 per cent., the form of the propeller blades not being a very good one.

The whole series of experiments is not given here in detail, but their principal results will be communicated in general terms. The first result is that the maximum efficiency of a propeller in air, as well as in water, is obtained with a small number of blades. A propeller with two blades gave nearly or quite as good results as one with a greater number. This is strikingly different from the form of the most efficient wind-mill, and it may be well to call attention to the essential difference in the character of the two instruments, and to the fact that the wind-mill and the movable propeller are not reversible engines, as they might at first sight seem to be. It is the stationary propeller—*i. e.*, the fan-blower—which is in reality the reversed wind-mill; and of these two, the most efficient form for one is essentially the most efficient form for the other. The efficiency of a fan-blower of given radius is expressed in terms of the quantity of air delivered in a unit of time for one unit of power put out; that of the wind-mill

may be expressed in terms of the amount of work done per unit quantity of air passing within the radius of the arms. If any air passes within the perimeter which does not strike the arms and do its work, it is so much loss of an attainable efficiency. This practical conclusion is confirmed by experience, since modern American wind-mills, in which practically the entire projection area is covered with the blades, are well known to be more efficient than the old wind-mills of four arms.

Turning now to the propeller, it will be seen that the expression for its efficiency, viz., the ratio of useful work done to power expended, involves quite different elements. Here the useful work done (in a unit of time) is the product of the resistance encountered by the distance advanced, which is entirely different in character from that in the fan-blower, and almost opposite conditions conduce to efficiency. Instead of aiming to set in motion the greatest amount of air, as in the case of the fan-blower, the most efficient propeller is that which sets in motion the least. The difference represents the difference between the screw working in the fluid without moving it at all, as in a solid nut, and actually setting it in motion and driving it backward—a difference analogous to that which in marine practice is technically called “slip,” and which is a part of the total loss of efficiency, since the object of the propeller is to drive itself forward and not to drive the air backward. It may now be seen why the propeller with few blades is more efficient than one with many. The numerous blades, following after each other quickly, meet air whose inertia has already yielded to the blades in advance, and hence that does not offer the same resistance as undisturbed air or afford the same forward thrust. In the case of the propeller with two blades, each blade constantly glides upon new strata of air and derives from the inertia of this fresh air the maximum forward thrust. The reader will observe the analogy here to the primary illustration of the single rapid skater upon thin ice, who advances in safety where a line of skaters, one behind the other, would altogether sink, because he utilizes all the sustaining power to be derived from the inertia of the ice and leaves only a sinking foothold for his successors. The analogy is not complete, owing to the actual elasticity of air and for other reasons, but the principle is the same. A second observation relating to aerial propellers, and one nearly related to the first, is that the higher the velocity of advance attained, the less is the percentage of “slip,” and hence the higher the efficiency of the propeller. The propeller of maximum efficiency is in theory one that glides through the air like a screw in an unyielding frictionless bearing, and obtains a reaction without setting the air in motion at all. Now, a reaction from the air arising from its inertia increases, in some ratio as yet undetermined, with the velocity with which it is struck, and if the velocity is high enough it is rendered probable, by facts not here recorded, that the reaction of this ordinarily

most mobile gas may be practically as great as we please and, with explosive velocities, for instance, may be as great as would be the reaction of a mass of iron.

The theory of aerial propellers being that for a maximum efficiency, the higher the velocity, the sharper should be the pitch of the blades, it has been the object of the complete series of experiments with the *Dynamometer-Chronograph* to determine by actual trial the velocity of advance at which the maximum efficiency is attained when the blades are set at different angles, and the best forms and dimensions of the blades. The details of these are reserved for future publication, but, very generally speaking, it may be said that notwithstanding the great difference between the character of the media, one being a light and very compressible, the other a dense and very incompressible fluid, these observations have indicated that there is a very considerable analogy between the best form of aerial and of marine propeller.

CHAPTER VIII.

THE COUNTERPOISED ECCENTRIC PLANE.

If a rectangular plane be made to move through the air at an angle of inclination with the direction of advance, it was implicitly assumed by Newton that the center of pressure would coincide with the center of figure. Such, however, is not the case, the pressure being always greater on the forward portion, and the center of pressure varying with the angle of inclination.

The object of the present chapter is to present the results of experiments made to determine the varying positions of the center of pressure for varying angles of inclination of a plane moved in a horizontal course through the air. Drawings of the apparatus devised for this purpose are given on plate V. AA' represents the eccentric wind-plane one foot square held in a brass frame about $\frac{1}{8}$ of an inch wide and $\frac{3}{8}$ of an inch thick. Two sliding pieces, SS', move in a groove in the edge of the brass frame, and may be clamped in any position by screws. Each sliding piece has a small central hole, in which fits a pivot, V. The wind-plane (*eccentric plane*) is suspended by these pivots and swings about the axis passing through them, so that by moving the plane in the sliding pieces this axis of rotation can be moved to any distance up to two inches. A flat lead weight, which also slides along the back of the plane, can be adjusted so as to counterpoise it in any position. When the weight is adjusted, therefore, the plane is in neutral equilibrium about its axis of rotation. A pencil, P, is fixed on the lower part of the plane and records against a tracing board perpendicular to it. In order to leave the position of the plane entirely uncontrolled by the friction of the pencil, the registering board is held away from the plane by spring hinges HH', and caused to vibrate by an electro-magnet so as to touch the pencil point many times in a second.

In the experiments the sliding pieces were set so that the axis of rotation was successively 0 inch, 0.25 inch, 0.75 inch, etc., from the center, and the plane was counterpoised about this axis. When placed in rotation upon the arm of the whirling-table, the moment of rotation of the plane about the axis is proportional to the resultant wind pressure multiplied by the distance of the center of pressure from the axis of rotation, and it will reach its position of equilibrium when the plane has taken up such an angle of inclination that the center of

pressure is at the axis of rotation. The measurement of this angle is, therefore, the object of observation.

In actual experiment the exact angle of equilibrium of the plane is masked by slight inequalities of speed and by fluctuation of the wind, and there is oscillation about a mean position. In measuring the trace, the extreme angles of this oscillation were read, as well as the mean position of equilibrium.

The following transcript from the note-book for September 22, 1888, will afford an illustration of the detailed records made in connection with each series of experiments. The column headed "range" gives the range of oscillation of the plane, and shows that the plane is far more unsteady when the axis of oscillation and center of pressure is very eccentric than when it is nearer the center.

SEPTEMBER 22, 1888.

Time.	Barometer. (Inches.)	Air tempera- ture. (Fahr.)	Wind direc- tion.	Air meter.
10.20 a. m.	29.080	58.9°	N. N. E.	183380
12.20 a. m.	29.069	61.2	N. N. E.	224065

Meteorological conditions not so favorable as yesterday, the wind being rather strong. Engine run by Eisler; J. Ludewig sets wind-plane; F. W. Very attends to chronograph and records.

Time.	Linear velocity of plane (meters per second).	Distance of axis of oscillation from center of plane (inches).	Angle of trace from vertical	Extreme angles of trace.	Range.
10.38 a. m.	12.8	2.00	82.0°	64°-98°	34°
10.42 a. m.	12.8	1.75	76.0	58-98	40
10.46 a. m.	12.8	1.75	76.0		
10.50 a. m.	12.9	1.50	68.0	48-84	36
.....					
12.12 p. m.	13.3	0.00	6.0	0.12	12

Two complete sets of observations were made, both on September 21 and September 22, 1888, making in all 31 separate readings, which are given in detail at the close of the chapter.

The mean of these observations is presented in the following table XVII:

TABLE XVII.

Summary of Experiments giving position of center of pressure on a plane one foot square (30.5 x 30.5 centimeters) for different angles of inclination.

Distance from center of pressure to center of plane d .		Distance as a percentage of the side of the plane.	Angle of trace with initial line.	Angle of plane with vertical $90^\circ - a$.	Angle of plane with horizontal a .
(Inches.)	(Centimeters.)				
0.00	0.00	0.000	5.5	0.0	90.0
0.25	0.64	0.021	17.4	12.0	78.0
0.50	1.27	0.042	28.2	22.7	67.3
0.75	1.90	0.063	39.7	34.2	55.8
1.00	2.54	0.083	50.6	45.0	45.0
1.25	3.17	0.104	59.7	54.2	35.8
1.50	3.81	0.125	67.5	62.0	28.0
1.75	4.44	0.146	75.0	69.5	20.5

The first two columns give the distance from the center of pressure to the center of the plane in centimeters and inches, and the third column gives it as a percentage of the length of the plane. The fourth column gives the angle of trace with the initial vertical line drawn through the position of the pencil at rest. It will be noticed that this angle is $5^\circ.5$ for the case when the axis of rotation passes through the center of the plane—a setting for which the plane must be vertical. This observed angle of $5^\circ.5$ is to be explained, not by a tipping of the plane, but by a tipping of the line of reference due to a yielding of the supports, etc., to the wind of rotation. This angular deflection, therefore, becomes a correction to be applied to all the observations, and the fifth column, headed “angle of plane with vertical,” contains the corrected values for the inclination of the plane.

The resulting relations here established between the angle of inclination of the plane and the position of the center of pressure are of importance, but their application is not made in the present memoir.*

*References to the results of Joëssel and of Kummer will be found in Appendix C.

Experiments to determine the position of the center of pressure on an inclined square plane.

SEPTEMBER 21, 1888.

F. W. VERY, *Conducting experiments*; JOSEPH LUDEWIG, *Assisting*.

Barometer, 737.06 mm.; temperature, 18° C.; wind velocity, 0.006 meter per second; length of side of wind-plane, 12 inches (30.5 centimeters).

Time.	Linear velocity of plane (meters per second).	Distance of axis of oscillation from center of plane.		Angle of trace from vertical.	Extreme angles of trace.	Range.
		(Inches.)	(Centimeters.)			
<i>p. m.</i>						
3.17	4.49	1.75	4.44	76.0	65-88°	23°
3.23	4.49	1.50	3.81	67.5	60-75	15
3.28	4.49	1.25	3.17	60.0	57-63	6
3.33	4.51	1.00	2.54	50.4	47-54	7
3.37	4.47	0.75	1.90	39.0	37-41	4
3.41	4.51	0.50	1.27	29.5	29-30	1
3.45	4.46	0.25	0.64	20.9	19-23	4
3.48	4.49	0.00	0.00	6.4	2-11	9
3.58	8.47	1.75	4.44	73.0	61-91	30
4.02	8.57	1.50	3.81	67.0	50-80	30
4.06	8.70	1.25	3.17	60.0	58-63	5
4.09	8.56	1.00	2.54	50.5	47-55	8
4.25	7.92	0.75	1.90	40.1	37-43	6
4.34	8.47	0.50	1.27	28.5	28-31	2
4.41	7.81	0.25	0.64	16.3	15-17	2
4.44	7.63	0.00	0.00	5.0	4-7	3

SEPTEMBER 22, 1888.

F. W. VERY, *Conducting experiments*; JOSEPH LUDEWIG, *Assisting*.

Barometer, 738.4 mm.; temperature, 15.°5 C.; wind velocity, 2.06 meters per second.

Meteorological conditions not so favorable as on the 21st, the wind being rather strong. The effect is to produce a much wider oscillation of the trace.

Time.	Linear velocity of plane (meters per second).	Distance of axis of oscillation from center of plane.		Angle of trace from vertical.	Extreme angles of trace.	Range.
		(Inches.)	(Centimeters.)			
<i>a. m.</i>						
10.38	12.8	2.00	5.08	82.0	64-98°	34°
10.42	12.8	1.75	4.44	76.0	58-98	40
10.46	12.8	1.75	4.44	76.0		
10.50	12.9	1.50	3.81	68.0	48-84	36
10.55	10.4	1.25	3.17	59.0	35-76	41
11.26	13.6	1.00	2.54	51.0	37-59	22
11.29	13.6	0.75	1.90	40.0	37-43	6
11.32	14.3	0.50	1.27	26.5	25-28	3
11.36	13.4	0.25	0.64	15.0	11-19	8
11.41	13.8	0.00	0.00	5.0	3-7	4
11.58	14.5	2.00	5.08	79.0	58-96	38
<i>p. m.</i>						
12.03	14.7	1.50	3.81	66.0	50-80	30
12.06	14.0	1.00	2.54	49.0	45-52	7
12.09	13.8	0.50	1.27	27.0	26-28	2
12.12	13.3	0.00	0.00	6.0	0-12	12

Note to Second Edition. The extreme forward position of the centre of pressure in these experiments was for the smallest angle, one-fourth the length of the plane from the front edge, but subsequent experiments, at Washington, with lighter planes have shown that it may be as little as one-sixth or even less. Moreover, it appears probable, though it is not demonstrated, that for an increased speed this centre of pressure tends to move forward even when there is no proposed diminution of the angle with the horizontal.

CHAPTER IX.

THE ROLLING CARRIAGE.

The *Rolling Carriage* was constructed for the purpose of determining the pressure of the air on a plane moving normal to its direction of advance.* Whatever be the importance of this subject to aerodynamics or engineering, we are here interested in it only in its direct bearing on the *aerodromic* problem, and carry these observations only as far as this special object demands. Before this instrument was constructed, a few results had already been obtained with the *Resultant Pressure Recorder* (chapter IV), but additional observations were desired with an instrument that would be susceptible of greater precision. The statement has frequently been made that the law that the pressure is proportional to the square of the velocity fails for low velocities as well as for very high ones. As it appears to me that this conclusion was probably based on imperfect instrumental conditions due to the relatively excessive influence of the friction of the apparatus at low velocities, particular pains were taken in the present experiments to get as frictionless an action as possible. Plates IX and X contain drawings in elevation and plan of the apparatus devised for this purpose.

A metal carriage $8\frac{1}{2}$ inches long is suspended on a set of delicately constructed brass wheels 5 inches in diameter, which roll on planed ways. Friction wheels bearing against the sides and bottom of the planed ways serve as guides to keep the carriage on its track. Cushions of rubber at each end break the force of any end-thrust. Through the center of this carriage passes a hollow brass rod $27\frac{1}{2}$ inches long, on the forward end of which is set the wind-plane by means of a socket at its center. On the other end is attached a spiral spring, which is also fastened by a hook to the rear of the carriage-track in a manner illustrated in the drawing. The rod is of such length that the wind-plane may be removed from the disturbing influence on the air of the mass of the registering apparatus, and the center of gravity of wind-plane and rod falls under the center of gravity of the carriage. The pressure of the wind on the wind-plane is bal-

*These measurements of pressure on the normal plane are not presented as new. They were made as a necessary part of an experimental investigation which aimed to take nothing on trust, or on authority however respectable, without verification. They are in one sense supplementary to the others, and although made early in the course of the investigations presented in this memoir, are here placed last, so as not to interrupt the presentation of the newer experiments, which are related to each other by a consecutive development.

anced by the extension of the spiral spring, while the *Rolling Carriage* bears an arm, F, carrying a pencil which rests upon a chronograph cylinder to automatically record this pressure, the axis of the cylinder being parallel to the track of the carriage and the chronograph rotated by clock-work. The position of the pencil for zero pressure on the spring is marked on the chronograph sheet, and a reference line is drawn through this point, so that distances of the pencil point from this reference line are measures of the extension of the spring, while a second pencil, being placed on the opposite side of the chronograph barrel, and operated by an electro-magnet in electrical connection with the mean time clock, registers seconds on the chronograph barrel, and thereby every point of the pressure trace made by the first pencil can be identified with the synchronous points in the trace on the stationary chronograph on which is registered the velocity of the whirling-table.

Much care was bestowed upon the manufacture and calibration of the spiral springs. The following is a list of the springs, giving their size, length, and weight:

Number.	Material.	Size of wire (Brown & Sharp gauge).	Length (inches).	Diameter of coil (inches).	Weight (grammes).
1	Steel ..	52	4.5	0.75	64
2	Brass ..	60	5.0	0.30	18
3	Steel ..	56	5.6	0.60	43
4	Steel ..	51	5.7	0.65	71
7	Steel ..	42	6.0	0.80	128

The method of calibration adopted is as follows:

The spring to be calibrated is fastened at one end to the brass tube of the *Rolling Carriage* and at the other to a fixed support. A string fastened to the end of the shaft passes over a light, almost frictionless pulley, and carries a bag, in which the weights are placed. The extensions of the spring are registered by the pencil on the chronograph barrel. Settings are made on opposite sides of a mean position, first, by letting the weight fall gradually to its lowest position; and, second, by extending it beyond its normal position and allowing the tension of the spring to draw it back. In both cases a series of vibrations are sent through the apparatus by the jar set up on the table, by means of a large tuning-fork, so as to overcome the friction of the moving parts. In a portion of the calibration experiments, these vibrations were produced by an electro-magnet.

The results of the calibration were plotted in curves, and these curves have been used for translating all the spring extensions of the experiments into pressures.

Three square planes were used, 6, 8, and 12 inches on a side, and in every case the center of the plane was placed nine meters from the center of the whirling-table. The air temperature was recorded at the beginning and end of each series of observations. The average wind velocity was obtained from a Casella air meter, which was read each day at the beginning and end of the experiments. It should be noted that these wind velocities are valuable as indicating the conditions of experiment, but do not afford any basis of correction to the observations, since the method adopted in reading the trace eliminates the effect of wind currents, so far as it is possible to do so. In a complete revolution of the turn-table the arm during half of the revolution moves with the wind, and during the other half moves against the wind; consequently the pressure will be too great during the latter half and too small during the former half of the revolution. Thus, if the velocity at the end of the arm be V , and the wind velocity be v , the wind pressure at one point of the revolution will be proportional to $(V + v)^2$, and at the opposite point will be proportional to $(V - v)^2$. The resulting trace, therefore, vibrates on either side of a mean position, and a line drawn through the trace to represent this mean position gives a numerical value that is larger than the pressure due to the velocity V in the ratio of $V^2 + v^2$ to V^2 . But, in general, this error in reading the traces is quite negligible, and the average mean position may be taken as reliable within the limits of accuracy imposed on us. The spring extension adopted always refers to this mean position, and no further correction is admissible. A specimen of the records of a series of experiments is here given in detail, taken from the note book for October 25, 1888:

OCTOBER 25, 1888.

Barometer, 738 mm.; mean temperature, 16° C. At 4.53 p. m., air meter, 416,445; at 5.25 p. m., air meter, 419,130. Eight-inch square wind-plane. Spring No. 1. Distance of center of plane from axis of rotation, 9 meters.

First registering sheet. Four records at about 4½ revolutions per minute. Ended at 4.05. Almost a perfect calm. Velocity too small to get reliable spring extensions.

Second sheet started at 4.24 p. m. Two records at 10 revolutions per minute. Ended at 4.28 p. m. Pencil failed to make satisfactory record.

Third sheet started at 4.34 p. m. at nearly 14 revolutions per minute. Four records obtained. Ended at 4.44 p. m.

Reading of traces.

Number of seconds in one revolution of turn-table.	Velocity of center of plane (meters per second).	Extension of spring No. 1 (inches).	Pressure on plane (pounds).
4.29	13.14	0.97	1.30
4.29	13.14	0.75	1.10
4.38	12.93	0.82	1.15
4.38	12.93	0.78	1.12

Fourth sheet. Velocity about 20 revolutions per minute. Two records obtained. Ended at 4.57 p. m.

Reading of traces.

Number of seconds in one revolution of turn-table.	Velocity of center of plane (meters per second).	Extension of spring No. 1 (inches).	Pressure on plane (pounds).
2.88	19.60	2.33	2.55
2.90	19.50	2.28	2.51

Fifth sheet. Velocity about 25 revolutions per minute. Two records obtained. The first record is good. The second record cannot be interpreted. Ended at 5.15 p. m.

Reading of traces.

Number of seconds in one revolution of turn-table.	Velocity of center of plane (meters per second).	Extension of spring No. 1 (inches).	Pressure on plane (pounds).
2.45	23.10	3.76	3.90

The experiments were made from October 24 to November 2, 1888, with a short series on November 28, 1890, and embrace observations with 6, 8, and 12 inch square planes, those with the 6-inch plane extending over velocities from 7 to 30 meters per second. They are presented *in extenso* at the end of the present chapter. The extension of the spring is given in inches, as originally measured from the trace, and the corresponding pressures are given in pounds and grammes. The next succeeding column gives the pressure P in grammes per square centimeter of the wind-plane surface. The last column gives the value of the coefficient k_m in the equation $P = k_m V^2$, where P is the pressure in grammes on a square centimeter of surface, and V the velocity expressed in meters per second. The subscript m is used here, as in previous chapters, to designate these metric units.

One of the objects of the experiments was to test the generally accepted law, that the pressure varies as the square of the velocity, and for this purpose

velocities were used ranging from 7 to 30 meters per second (11 to 67 miles per hour). The mean of 10 observations with the 6-inch plane, at velocities between 25 and 30 meters per second, gave $k_m = 0.0081$; and the mean of 12 observations, at velocities between 7.1 and 14.3 meters per second, gave the same value. Therefore the departure from the law of the squares, if there be any between these limits of velocity, is not sufficiently large to be detected by this apparatus.

If variations in the density of the air produced by changes of temperature be considered in their effect upon the relation between pressure and velocity, the preceding formula may be expressed in the form

$$P = \frac{k_m V^2}{1 + .00366 (t - 10^\circ)}$$

where .00366 is the coefficient of expansion of air per centigrade degree; t is the temperature of the air expressed in centigrade degrees, and k_m is the value of the coefficient for a standard temperature of 10° C. In the following summary, all the values of k_m are collected and reduced by aid of this formula to a common mean temperature of 10° C.; the values refer, also, to a mean barometric pressure of 736 mm. An additional column is added, giving the corresponding value of k in English measures for velocities expressed in feet per second and pressures in pounds per square foot.

TABLE XVIII.
Summary of values of k_m obtained with the Rolling Carriage.

Size of plane.	Date.	Number of observations.	Temperature C°.	k_m .	k_m , for $t = 10^\circ$ C.	k , for $t = 10^\circ$ C.
12 inches square.	1888.					
	Oct., 24	9	10.0	0.01027	0.01027	
	" 30	11	7.8	0.00913	0.00906	
	Nov. 2	4	19.0	0.00830	0.00859	
	1890.					
Nov. 28	3	— 2.0	0.00990	0.00948		
			Weighted mean		0.00944	0.00180
6 inches square.	1888.					
	Oct. 24	3	10.0	0.00760	0.00760	
	" 29	6	12.0	0.00785	0.00790	
	Nov. 1	12	20.0	0.00810	0.00840	
	" 2	13	19.0	0.00840	0.00867	
			Weighted mean		0.00833	
8 inches square.	Oct. 25	7	16.0	0.00754	0.00770	0.00147
				General weighted mean.	0.0087	0.00166

The resulting values of k_m for the 6, 8, and 12 inch square planes are not entirely accordant, as the successive sets of observations with the 12-inch plane all give considerably larger values than those obtained with the smaller planes. I am not disposed, however, to consider this as a real effect due to an actual difference in the pressure per unit area on these planes. Such a difference, if one exists, is in all probability quite small, and much within the degree of accuracy possessed by these experiments. The resulting differences in the mean values of k_m I consider, therefore, as discrepancies in the observations, the cause of which has not become apparent. In recognition, however, of the fact that other experimenters have claimed to discover a difference in the pressure per unit area on planes of different sizes, I have, in general, in the preceding chapters, taken pains to specify the area of the plane to which all my experimental results apply. That there should be a real, though perhaps a small, difference between the pressure per unit area on planes of different sizes seems in fact quite probable, when we consider that the ratio of perimeter to area varies for similar shaped planes of different sizes. If the side of a square plane be a and that of another be na , the ratio of perimeter to surface is $\frac{4}{a}$ in the one case and $\frac{4}{na}$ in the other, which is not merely an expression of a mathematical relation, but calls attention to a possibly important physical fact, for it seems probable that this relation between perimeter and area has a considerable influence in determining the pressure on the plane, especially that part of it produced by the diminution of pressure on its posterior face.

The general weighted mean of all the values of k_m is .0087, or, in English measures, $k^* = .00166$, and I believe this result is within 10 per cent. of the true value. These experiments lead me to place the limits of the value of k_m for a 1-foot square plane, between 0.0078 ($k = .0015$) and 0.0095 ($k = .0018$) for the assumed temperature of 10° C., and pressure 736 mm., and, made as they were in the open air and subject to wind currents, they are not sufficiently precise to give more contracted limits. It may be noted that the value of k_m obtained from the experiments with the *Resultant Pressure Recorder*, viz., $k_m = .0080$, falls between the probable limits above assigned, and is within the probable uncertainty (10 per cent.) of the mean of the results with the *Rolling Carriage*. The *Rolling Carriage*, therefore, although a very sensitive and delicate piece of apparatus, has not been able under the conditions of experiment to yield a sensibly better result than the rougher instrument.

**Note to Second Edition.* k here is the total effect of pressure before, and suction behind, and has the same meaning as Newton's *resistentia* (Principia Prop. XXXVII). It is the total effect of a wind of 1 foot per second on 1 square foot. A velocity of 1 foot per second is gained by falling in vacuo from a height $h = 0^{\text{ft}}.0155$ and the weight of a column of air of this height and 1 square foot in base is $0^{\text{lbs}}.00128$ which is what the so-called Newtonian theorem gives as the value of the pressure on the front face. To get the total resistance (always greater) this must be multiplied by some factor K . In this case the value of K is $\frac{.00166}{.00128} = 1.30$.

Measurement of wind pressure on normal planes by means of the Rolling Carriage.

OCTOBER 24, 1888.

PRESSURE ON ONE-FOOT SQUARE PLANE (929 square centimeters).

Barometer, 735 mm.; mean temperature, 10°.0 C.; wind velocity, 2.8 meters per second.

Time of observation.	Number of revolutions of turn-table per minute.	Velocity of center of plane V (meters per second).	Extension of spring No. 1 (inches).	Pressure on wind-plane.			$k_m = \frac{P}{V^2}$
				(Pounds.)	(Grammes.)	P (grammes per square centimeter).	
1.20 p. m.	14.00	13.18	3.39	3.55	1,610	1.73	0.0100
	14.00	13.18	3.62	3.84	1,740	1.87	0.0108
1.40 p. m.	9.49	8.92	1.42	1.71	776	0.83	0.0105
	9.49	8.92	1.42	1.71	776	0.83	0.0105
2.00 p. m.	5.50	5.15	0.32	0.58	263	0.28	0.0107
	5.60	5.28	0.30	0.53	240	0.26	0.0093
2.15 p. m.	14.90	14.03	3.90	3.99	1,810	1.95	0.0099
	15.00	14.09	4.10	4.19	1,900	2.04	0.0104
	14.80	13.91	4.00	4.08	1,850	1.99	0.0103
						Mean =	0.01027

PRESSURE ON SIX-INCH SQUARE PLANE (232 square centimeters).

Time of observation.	Number of seconds in one revolution of turn-table.	Velocity of center of plane V (meters per second).	Extension of spring No. 1 (inches).	Pressure on wind-plane.			$k_m = \frac{P}{V^2}$
				(Pounds.)	(Grammes.)	P (grammes per square centimeter).	
4.00 p. m.	2.32	24.3	1.93	2.18	990	4.26	0.0072
	2.52	23.8	1.97	2.22	1,008	4.34	0.0077
	2.52	23.8	2.05	2.29	1,040	4.48	0.0079
						Mean =	0.0076

OCTOBER 25, 1888.

PRESSURE ON EIGHT-INCH SQUARE PLANE (413 square centimeters).

Barometer, 738 mm.; mean temperature, 16°.0 C.; wind velocity, 0.6 meter per second.

Time of observation.	Number of seconds in one revolution of turn-table.	Velocity of center of plane V (meters per second).	Extension of spring No. 1 (inches).	Pressure on wind-plane.			$k_m = \frac{P}{V^2}$
				(Pounds.)	(Grammes.)	P (grammes per square centimeter).	
4.30 p. m.	4.29	13.14	0.97	1.30	590	1.43	0.0083
	4.29	13.14	0.75	1.10	499	1.21	0.0070
	4.38	12.93	0.82	1.15	522	1.26	0.0075
	4.38	12.93	0.78	1.12	508	1.23	0.0074
	2.88	19.60	2.33	2.55	1,157	2.80	0.0073
	2.90	19.50	2.28	2.51	1,139	2.76	0.0073
5.15 p. m.	2.45	23.10	3.76	3.90	1,770	4.29	0.0080
	Mean =						0.00754

OCTOBER 29, 1888.

PRESSURE ON SIX-INCH SQUARE PLANE (232 square centimeters).

Barometer, 735 mm.; mean temperature, 12°.0 C.; wind velocity at 1 p. m., 3.3 meters per second.

Time of observation.	Number of seconds in one revolution of turn-table.	Velocity of center of plane V (meters per second).	Extension of spring No. 1 (inches).	Pressure on wind-plane.			$k_m = \frac{P}{V^2}$
				(Pounds.)	(Grammes.)	P (grammes per square centimeter).	
4.24 p. m.	2.15	26.30	3.00	3.20	1,450	6.25	0.0090
4.28 p. m.	2.03	27.85	3.08	3.26	1,480	6.38	0.0082
4.33 p. m.	1.88	30.15	3.41	3.57	1,620	6.98	0.0077
4.37 p. m.	1.93	29.20	3.19	3.35	1,520	6.55	0.0077
5.29 p. m.	4.29	13.20	0.36	0.61	277	1.19	0.0068
5.33 p. m.	3.95	14.30	0.50	0.80	363	1.57	0.0077
Mean =						0.00785	

OCTOBER 30, 1888.

PRESSURE ON ONE-FOOT SQUARE PLANE (929 square centimeters).

Barometer, 739 mm.; mean temperature, 7°.8 C.; wind velocity, —.

	Number of seconds in one revolution of turn-table.	Velocity of center of plane V (meters per second).	Extension of spring No. 1 (inches.)	Pressure on wind-plane.			$k_m = \frac{P}{V^2}$
				(Pounds.)	(Grammes.)	P (grammes per square centimeter).	
	7.23	7.84	0.88	1.20	544	0.586	0.0095
	10.14	5.58	0.25	0.50	227	0.244	0.0079
	7.89	7.17	0.69	1.01	458	0.493	0.0096
	10.86	5.22	0.27	0.51	231	0.249	0.0092
	11.32	5.00	0.28	0.52	236	0.254	0.0102
	8.56	6.62	0.47	0.75	340	0.366	0.0084
	6.64	8.51	1.00	1.30	589	0.634	0.0088
	6.74	8.39	1.00	1.30	589	0.634	0.0090
	6.30	8.98	1.33	1.62	734	0.790	0.0098
	6.20	9.12	1.34	1.63	739	0.796	0.0096
	5.93	9.54	1.27	1.56	707	0.761	0.0084
						Mean =	0.00913

NOVEMBER 1, 1888.

PRESSURE ON SIX-INCH SQUARE PLANE (232 square centimeters).

Barometer, 741 mm.; mean temperature, 20°.0 C.; wind velocity, 1.5 meters per second.

Time of observation.	Number of seconds in one revolution of turn-table.	Velocity of center of plane V (meters per second).	Extension of spring No. 2 (inches.)	Pressure on wind-plane.			$k_m = \frac{P}{V^2}$	
				(Pounds.)	(Grammes.)	P (grammes) per square centimeter).		
3.30 p. m.	4.35	13.00	1.60	0.78	356	1.53	0.0091	
	4.32	13.10	1.43	0.70	320	1.38	0.0080	
	3.99	14.20	2.19	1.04	472	2.03	0.0100	
	4.00	14.14	2.07	0.99	449	1.93	0.0096	
	4.00	14.14	1.60	0.78	356	1.53	0.0077	
	3.96	14.30	1.58	0.78	354	1.53	0.0075	
	5.64	10.00	0.64	0.36	163	0.70	0.0070	
	5.67	9.97	0.61	0.35	159	0.69	0.0069	
	5.40	10.47	0.80	0.43	197	0.85	0.0077	
	5.51	10.26	0.69	0.38	174	0.75	0.0071	
	7.93	7.13	0.30	0.20	91	0.39	0.0077	
	5.25 p. m.	7.60	7.44	0.40	0.25	113	0.49	0.0089
							Mean =	0.00810

NOVEMBER 2, 1888.

PRESSURE ON SIX-INCH SQUARE PLANE (232 square centimeters).

Barometer, 735.6 mm.; mean temperature, 19°.0 C.; wind velocity, 1.5 meters per second.

Time of observation.	Number of seconds in one revolution of turn-table.	Velocity of center of plane <i>V</i> (meters per second).	Extension of spring No. 4 (inches).	Pressure on wind-plane.			$k_m = \frac{P}{V^2}$	
				(Pounds.)	(Grammes.)	<i>P</i> (grammes per square centimeter).		
11.00 a. m.	2.14	26.40	2.92	3.11	1,411	6.08	0.0087	
	2.13	26.55	2.62	2.85	1,294	5.56	0.0079	
	2.43	23.30	2.27	2.52	1,143	4.92	0.0091	
	2.73	20.70	1.80	2.10	953	4.10	0.0096	
	2.91	19.40	1.32	1.67	758	3.26	0.0087	
	5.66	10.00	0.16	0.45	204	0.88	0.0088	
	3.72	15.20	0.52	0.90	408	1.76	0.0076	
	3.62	15.60	0.53	0.91	413	1.78	0.0073	
	3.10	18.20	1.19	1.54	699	3.01	0.0091	
	2.03	27.85	3.49	3.63	1,646	7.09	0.0091	
	2.03	27.80	3.08	3.27	1,484	6.38	0.0083	
	1.99	28.40	3.00	3.19	1,448	6.22	0.0077	
	1.94	29.10	2.84	3.04	1,380	5.93	0.0070	
							Mean =	0.0084

PRESSURE ON ONE-FOOT SQUARE PLANE (929 square centimeters).

Note: Wind too high for best results.

Time of observation.	Number of seconds in one revolution of turn-table.	Velocity of center of plane <i>V</i> (meters per second).	Extension of spring No. 7 (inches).	Pressure on wind-plane.			$k_m = \frac{P}{V^2}$
				(Pounds.)	(Grammes.)	<i>P</i> (grammes per square centimeter).	
1.50 p. m.	2.27	24.9	2.28	10.60	4,810	5.18	0.0084
	2.34	24.1	1.92	9.05	4,105	4.42	0.0076
	2.90	19.5	1.28	6.25	2,835	3.05	0.0080
	3.10	18.2	1.27	6.20	2,810	3.03	0.0092
						Mean =	0.0083

NOVEMBER 28, 1890.

PRESSURE ON ONE-FOOT SQUARE PLANE (929 square centimeters).

Barometer, 737 mm.; mean temperature, $-2^{\circ}.0$ C.; wind velocity, 1.2 meters per second.

Time of observation.	Number of seconds in one revolution of turn-table.	Velocity of center of plane V (meters per second).	Extension of spring No. 1 (inches).	Pressure on wind-plane.			$k_m = \frac{P}{V^2}$
				(Pounds.)	(Grammes.)	P (grammes per square centimeter).	
	4.8	11.8	2.60	2.80	1,270	1.37	0.0099
	5.0	11.3	2.40	2.60	1,179	1.27	0.0099
	4.9	11.5	2.48	2.68	1,216	1.31	0.0099

CHAPTER X.

SUMMARY.

The essential feature of the present work has been the insistence on the importance of a somewhat unfamiliar idea—that rapid aerial locomotion can be effected by taking advantage of the inertia of the air and its elasticity. Though the fact that the air has inertia is a familiar one, and though the flight of certain missiles has indicated that this inertia may be utilized to support bodies in rapid motion, the importance of the deductions to be made has not been recognized. This work makes the importance of some of these deductions evident by experiment, and perhaps for the first time exhibits them in their true import.

This memoir is essentially a presentation of experiments alone, without hypotheses, and with only such indispensable formulæ as are needed to link the observations together. These experiments furnish results which may be succinctly summarized as follows:

The primary experiment with the *Suspended Plane* is not intended *per se* to establish a new fact, but to enforce attention to the neglected consequences of the fundamental principle that the pressure of a fluid is always normal to a surface moving in it, some of these consequences being (1) that the stress necessary to sustain a body in the air is less when this is in horizontal motion than when at rest; (2) that this stress instead of increasing, diminishes with the increase of the horizontal velocity (a fact at variance with the conclusions of some physicists of repute and with ideas still popularly held); (3) that it is at least probable that in such horizontal flight up to great velocities the greater the speed the less the power required to maintain it, this probability being already indicated by this illustrative experiment, while demonstrative evidence follows later.

The experiments which are presented in Chapter IV result in an empirical curve, giving the ratio between the pressure on an inclined square plane and on a normal plane moving in the air with the same velocity. Incidentally it is shown that the pressure is normal to the inclined surface, and hence that the effects of skin-friction, viscosity, and the like are negligible in such experiments. It is also shown that for the small angles most used in actual trial of the plane, the pressure on it is about 20 times greater than that assignable from the theoretical formula derived from Newton's discussion of this subject in the *Principia*. This

last experimental result is not presented as a new contribution to knowledge, since it had previously been obtained by experimenters in the early part of this century; but as their results appear not to have met with the general attention or acceptance they deserve, it is not superfluous either to produce this independent experimental evidence or to urge its importance.

The experiments with the *Plane-Dropper* introduce matter believed to be novel as well as important. They show (1) that the time of falling of a horizontal plane is greater when moving horizontally than when at rest, and (2) that this time of falling most notably increases with the velocity of lateral translation; (3) experiments with different horizontal planes show that this increase in the time of falling is greater for those planes whose extension from front to back is small compared with their length measured perpendicular to the line of advance, (4) the horizontal velocities are determined at which variously shaped inclined planes set at varying angles can *soar*—that is, just sustain their own weight in the air under such circumstances—and these data afford the numerical basis for the important proposition that the power required to maintain the horizontal motion of an inclined aeroplane is less for high speeds than for low ones; (5) by experiments with double planes, one above the other, it is shown that planes of the advantageous shape mentioned above, do not interfere with each other at specified speeds, if so placed at an interval not less than their length from front to back; and it is pointed out that an extension of this method enables us to determine the extent to which any underlying air stratum is disturbed during the plane's passage.

Chapter VI contains further data, which confirm the important conclusions derived from the experiments with the *Plane-Dropper*, already cited, and some results on the pressures on inclined planes having different "aspects" with reference to the direction of motion are also presented, which are believed to be new and of importance. Further chapters present experiments with a special instrument called the *Dynamometer-Chronograph* and with other apparatus, which give data regarding aerial propellers, a series of experiments on the center of pressure of moving planes, and another series upon the pressure on a normal plane.

The conclusions as to the weights which can be transported in horizontal flight have included the experimental demonstration that the air friction is negligible within the limits of experiment. It has not been thought necessary to present any evidence that an engine or other adjunct which might be applied to give these planes motion, need itself oppose no other than frictional resistance, if enclosed in a stream-line form, since the fact that such forms oppose no other resistance whatever to fluid motion, has been abundantly demonstrated by Froude, Rankine, and others.

The most important general inference from these experiments, as a whole, is that, so far as the mere power to sustain heavy bodies in the air by mechanical flight goes, *such mechanical flight is possible with engines we now possess*, since effective steam-engines have lately been built weighing less than 10 pounds to one horse-power, and the experiments show that if we multiply the small planes which have been actually used, or assume a larger plane to have approximately the properties of similar small ones, one horse-power rightly applied, can sustain over 200 pounds in the air at a horizontal velocity of over 20 meters per second (about 45 miles an hour), and still more at still higher velocities. These numerical values are contained in the following table, repeated from p. 66. It is scarcely necessary to observe that the planes have been designedly loaded, till they weighed 500 grammes each, and that such a system, if used for actual flight, need weigh but a small fraction of this amount, leaving the rest of the sustainable weight indicated, disposable for engines and other purposes. I have found in experiment that surfaces approximately plane and of $\frac{1}{10}$ this weight are sufficiently strong for all necessary purposes of support.

Data for soaring of 30 x 4.8 inch planes; weight, 500 grammes.

Angle with horizon α .	Soaring speed V .		Work expended per minute.		Weight with planes of like form that 1 horse-power will drive through the air at velocity V .*	
	Meters per second.	Feet per second.	Kilogram-meters.	Foot-pounds.	Kilogrammes.	Pounds.
45	11.2	36.7	336	2,434	6.8	15
30	10.6	34.8	175	1,268	13.0	29
15	11.2	36.7	86	623	26.5	58
10	12.4	40.7	65	474	34.8	77
5	15.2	49.8	41	297	55.5	122
2	20.0	65.6	24	174	95.0	209

*Footnote to Second Edition. If this last statement had not been misunderstood, it would seem superfluous to say that it refers not to an actual flying machine, with the limitations on speed imposed in construction by guys, framing, etc., and by the loss in transmission of horse-power between that generated in the engine and that delivered in thrust-speed. It refers to the ideal condition of the frictionless plane, as closely determined by the foregoing experiments.

These remarks are also to be borne in mind in interpreting the following formula, which is only a summary of results given elsewhere in the book.

From the fundamental formulæ on page 60, if the weight W be one pound; the area A one square foot, then the velocity V at which the normal movement of the plane is constant will equal nearly $24\frac{1}{2}$ feet per second (where k [experimentally determined] equals 0.00166). If from this we pass to the more extended case where the plane is no longer normal but inclined at an angle α , and $F(\alpha)$ is supposed to be of the form $\frac{2 \sin \alpha}{1 + \sin^2 \alpha}$, then using the foot, pound, second units we have the following formula for the horse power required to propel an aerodrome supported by thin frictionless planes:

Energy expended = $R V$, but from page 60 we have $W = k A V^2 F(\alpha) \cos \alpha$, \therefore

$V = \sqrt{\frac{W}{k A F(\alpha) \cos \alpha}}$, also $R = W \tan \alpha$, but in the foot, pound, second system of units, Horse Power =

$$\frac{R V}{550}, \therefore H P = \frac{W \tan \alpha \sqrt{\frac{W}{k A F(\alpha) \cos \alpha}}}{550} = \frac{W^{3/2} \sin \alpha}{550 \cos^{3/2} \alpha \sqrt{A k F(\alpha)}}$$

If for the planes we substitute certain curved surfaces, the power may be materially less; but the discussion of this part of the subject, as well as that regarding the frictional resistances caused by the necessary framing, etc., the loss of power between the engine and the actual delivered thrust-speed in an actual machine, does not belong to the present volume.

I am not prepared to say that the relations of power, area, weight, and speed, here experimentally established for planes of small area, will hold for indefinitely large ones; but from all the circumstances of experiment, I can entertain no doubt that they do so hold far enough to afford assurance that we can transport, (with fuel for a considerable journey and at speeds high enough to make us independent of ordinary winds,) weights many times greater than that of a man.

In this mode of supporting a body in the air, its specific gravity, instead of being as heretofore a matter of primary importance, is a matter of indifference, the support being derived essentially from the inertia and elasticity of the air on which the body is made to rapidly run. The most important and it is believed novel truth, already announced, immediately follows from what has been shown, that whereas in land or marine transport increased speed is maintained only by a disproportionate expenditure of power, within the limits of experiment in *such aerial horizontal transport, the higher speeds are more economical of power than the lower ones.*

While calling attention to these important and as yet little known truths, I desire to add as a final caution, that I have not asserted that planes such as are here employed in experiment, or even that planes of any kind, are the best forms to use in mechanical flight, and that I have also not asserted, without qualification, that mechanical flight is practically possible,* since this involves questions as to the method of constructing the mechanism, of securing its safe ascent and descent, and also of securing the indispensable condition for the economic use of the power I have shown to be at our disposal—the condition, I mean, of our ability to guide it in the desired horizontal direction during transport,—questions which, in my opinion, are only to be answered by further experiment, and which belong to the inchoate art or science of *aerodromics*, on which I do not enter.

I wish, however, to put on record my belief that the time has come for these questions to engage the serious attention, not only of engineers, but of all interested in the possibly near practical solution of a problem, one of the most important in its consequences, of any which has ever presented itself in mechanics; for this solution, it is here shown, cannot longer be considered beyond our capacity to reach.*

**Footnote to Second Edition.* Since the preceding lines were written the writer has demonstrated that mechanical flight *is* possible by actually performing it with steel flying machines nearly a thousand times heavier than the air, driven by steam, and employing as a rule curved sustaining surfaces. These machines, which were built by the writer, weighed from thirty to forty pounds, and they have arisen and descended in safety, their flight being limited intentionally to distances of from $\frac{1}{2}$ a mile to $\frac{3}{4}$ of a mile, at speeds varying from 20 to 30 miles an hour. (See *Nature*, Vol. 54, May 28, 1896.)

The "inchoate art" of aerodromics has since made a corresponding progress, and, while leaving a great deal to be done, it is believed by the writer that the time is now very near when human beings will be transported at high velocities, though perhaps at first under exceptional conditions such as are demanded in the arts of war rather than of peace.

APPENDIX A.

I append here the results of some additional experiments made with the *Plane-Dropper* to determine the law of falling of a horizontal plane having a horizontal velocity of translation. It will be recalled that the preceding data given in the chapter on the *Plane-Dropper* show only the total time of falling a distance of four feet, and that we cannot determine from it the law of fall, unless we know, in addition, the relative diminution in the acceleration during the descent, and whether at the end of the fall the plane has attained an approximately constant velocity. For high horizontal velocities and for the most advantageous planes, it is not impossible that an approximately constant velocity is reached within the four-foot fall of the *Plane-Dropper*. In order to obtain these additional data, I placed electric contacts upon the *Plane-Dropper* at intervals of every foot, and introduced other modifications into the method of experiment. The accuracy with which it was necessary to measure the relative times of fall through successive feet precluded the further use of the stationary chronograph for the registration, and I adapted a König chronoscope to this purpose.

This chronoscope consists of a tuning-fork of low pitch, which is made to vibrate by the action of an electro-magnet. The vibrations are registered by a pen-point on a strip of paper covered with lamp-black, which is passed over a roller during the time of fall. A second pen-point worked by an electro-magnet records the passage of the falling-piece over the five successive contact-pieces of the *Plane-Dropper*. On the same strip, therefore, we have the relative intervals between the successive contacts, and a time-scale for their evaluation. Although not essential for the evaluation of the intervals, approximate uniformity in the motion of the strip of paper was obtained by fastening to the ends brass clips differing suitably in weight, and converting this part of the apparatus into an Atwood's machine.

Two separate batteries were used, an electro-pion battery of four cells, equivalent to thirty or forty Daniel's cells, for vibrating the tuning-fork, and an ordinary battery of eight cells for the *Plane-Dropper* and the quadrant contacts of the turn-table. The current from this battery is forked into two branches, one branch running to the quadrant contacts of the turn-table and to the observatory chronograph on which they register; the other branch, going to the *Plane-Dropper*, actuates the release magnet, passes through the five electric contacts, and thence goes to the electro-magnet on the König chronoscope, where these contacts are registered, and finally back to the battery. This circuit is closed by a make-key in the hands of the operator at the chronoscope.

A preliminary calibration of the tuning-fork was made by connecting one pen of the chronoscope with the mean time-clock, and obtaining a number of strips containing both second intervals and tuning-fork vibrations.

*Calibration of tuning-fork.*DECEMBER 12, 1890.—G. E. CURTIS, *Observer.*

Temperature of tuning-fork, 18° C.

Number of strip.	Number of vibrations of fork per second.		
	1st second.	2d second.	Mean of 2 seconds.
1	-----	-----	49.9
3	48.6		
4	48.2	51.9	
	47.8		
5	48.8	51.0	
	48.6	50.8	
	48.8		

Mean, 49.9 vibrations per second.

The measurement of the strips showed that the clock was not "on beat," and that two successive seconds must be taken in order to get the true interval. The mean of the measurements gave 49.9 vibrations per second. The tuning-fork was evidently constructed to give 50.0 vibrations per second, and this value was therefore adopted. The fraction of a vibration can be accurately estimated to tenths; hence the instrument, as used in these observations, gave time intervals to $\frac{1}{500}$ part of a second, which is sufficiently accurate for the purpose.

Preliminary experiments were made with the *Plane-Dropper* at rest indoors for the purpose of testing the new contacts and the König registration apparatus. The pair of 12 x 6 inch planes were fastened horizontally to the falling piece. Then the observer, with one hand, sets in motion the blackened strip on the König, and with the other, immediately thereafter, presses the make-key, which operates the release magnet of the *Plane-Dropper*. The blackened strip containing the registration is then passed through a solution of shellac and ammonia, by which the trace is permanently set.

The result of these preliminary experiments is as follows:

*Time of fall of pair of 12 x 6 inch planes, horizontal.*DECEMBER 10, 1890.—G. E. CURTIS, *Observer.*

	Observed time of fall (seconds).	Theoretical time (in vacuo).	Difference.
1st foot -----	0.220	0.250	
2d foot -----	0.110	0.104	+ .006
3d foot -----	0.090	0.080	.010
4th foot -----	0.080	0.066	+ .014
Total, 4 feet -----	0.500	0.500	

The first contact is not at absolute rest, but a fraction (0.4 or 0.5) of an inch below the position of rest; hence, when it records, the plane has already attained a small velocity. To this is due the fact that the time of falling the first foot, which is registered by the first and second contacts, is less than the computed time *in vacuo* by .03 second. At least this amount should therefore be added to the observed time for the first foot, and the total time will be 0.53 seconds. This gives a total retardation of 0.03 seconds, due to the resistance of the air. Attention is called to the symmetrical character of the differences between the observed and the computed time *in vacuo*, showing the increasing retardation corresponding to increasing velocities of fall. Being assured by these results of the perfect adaptation of the apparatus to secure the desired data, the *Plane-Dropper* was placed upon the whirling-table December 13, 1890.

When the whirling-table has attained uniform motion at the speed desired, a signal is given to the observer seated at the König chronoscope to proceed with the experiment. First, by a break-key he cuts out for a moment the quadrant contacts as an evidence on the chronograph sheet of the time of the experiment. Second, the chronoscope strip, which has previously been prepared and placed upon the roller, is set in motion by the release of a detent, and an instant later, when the strip has gotten fully into motion, the make-key of the *Plane-Dropper* circuit is pressed, releasing the falling plane. As the falling plane passes each of the five contact pieces the circuit is completed, and registration is made upon the König strip. In two seconds after setting in motion the König strip the experiment is at an end. The strip containing the record is then passed through the solution of shellac and alcohol for setting the trace, after which it is measured at leisure. Meanwhile a new strip is placed upon the chronoscope, and the apparatus is in readiness for another trial.

The results of the observations covering a range of horizontal velocity from 6 to 26 meters per second (13.5 to 58.5 miles per hour) are contained in the accompanying table.

To find the times of falling successive feet of planes having a horizontal velocity.

DECEMBER 13, 1890.

F. W. VERY, G. E. CURTIS, *Observers.*

One pair 12 x 6 inch planes horizontal; weight, 464 grammes (1.02 lbs.); mean temperature, 0° C.; wind velocity, 1.85 meters per second.

TIMES OF FALL AT DIFFERENT HORIZONTAL VELOCITIES.

Horizontal velocity (meters per second).	At rest.			6.0	11.9	12.0	12.1	14.6	14.4	18.0	22.1	26.2
	1st foot -----	0.218	0.314	0.284	0.389	0.429	0.334	0.448	0.678	0.930	0.600	1.440
2d foot -----	0.112	0.120	0.111	0.125	0.257	0.205	0.147	0.202	0.450	0.220	0.285	0.303
3d foot -----	0.089	0.094	0.088	0.105	-----	0.213	0.166	0.360	0.306	0.340	0.280	0.399
4th foot -----	0.079	0.082	0.077	0.098	-----	0.235	0.190	-----	-----	0.180	-----	0.487
Total, 4 feet--	0.498	0.610	0.560	0.717	-----	1.487*	0.951	-----	-----	1.340	2.005	2.151

* Seriously affected by wind.

SUMMARY.

Velocity (meters per second).	Time of falling 4 feet.	Increase over time in vacuo.
0.0	0.55	0.05
6.0	0.72	0.22
12.0	0.95	0.45
18.0	1.34	0.84
22.0	2.00	1.50
26.0	2.15	1.65

The time of falling the total 4 feet increases from 0.55 second, when the plane is at rest, to 2.15 seconds, when the plane has a horizontal velocity of 26 meters per second. Examining the time of falling the several successive feet, it will be seen that there is no uniformity in the relative times in which the several distances were passed over. Only the first experiment at 6 meters per second shows a velocity of fall continually increasing at a diminishing rate as the circumstances require. The remaining four experiments, for which a complete record was obtained, show decreasing velocities of fall in a part or all of the distance after the first foot. These anomalous and discordant results are in all probability due to wind currents having a vertical component, which vitiated the observations. Thus the completeness of the apparatus and the perfection of the details of operations, whereby an accuracy of $\frac{1}{500}$ of a second was secured, were all rendered futile by the uncontrolled conditions under which the experiment was unavoidably conducted, and no decisive result was added to those already summarized.

APPENDIX B.

Mr. G. E. Curtis calls my attention to the fact that the conclusion that the power required to maintain the horizontal flight of an aeroplane diminishes with the increasing speeds that it attains, may be deductively shown by the following analysis:

Representing the work to be done per second by T , the resistance to horizontal motion by R , and the horizontal velocity by V , we have by definition

$$T = RV.$$

Substituting for R its value, $W \tan a$ (see p. 65), W being the weight of the plane, we have the equation

$$T = VW \tan a,$$

in which a and V are dependent variables. The curves of soaring speed (Fig. 9) enable us, in the case of a few planes, to express a in terms of V , but, for any plane and without actually obtaining an analytical relation between V and a , we may determine the character of the function T , *i. e.*, whether it increases or decreases with V , in the following manner:

Differentiating with respect to V , we obtain

$$\frac{dT}{dV} = W \left(\tan a + V \sec^2 a \frac{da}{dV} \right).$$

Now, since in flight a is a very small angle, $\tan a$ will be small as compared with the term $V \sec^2 a \frac{da}{dV}$. Hence the sign of the latter factor $\frac{da}{dV}$ will control the sign of $\frac{dT}{dV}$.

Now, since V increases as a diminishes, $\frac{da}{dV}$ is negative, which makes the term $V \sec^2 a \frac{da}{dV}$ negative, and therefore, in general, T is a decreasing function of V . In other words, neglecting the skin friction and also any end pressure that there may be on the plane, the work to be done against resistance in the horizontal flight of an inclined plane must diminish as the velocity increases.

APPENDIX C.

At the time of my experiments to determine the varying position of the center of pressure on an inclined plane moving in the air, I was unacquainted with the similar experimental work of Joëssel* and of Kummer† in the same field. Joëssel, who appears to be the first experimenter on the subject, found for a square plane of length L that, as the angle between the plane and the current is diminished, the center of pressure approaches a point $\frac{1}{5} L$ from the forward edge, and that its position for any angle a between the plane and the current may be represented by the formula

$$d = (0.3 - 0.3 \sin a) L,$$

d being the distance of the center of pressure from the center of plane.

The method of experiment adopted by Kummer is essentially similar to the one pursued by me in the use of the *Counterpoised Eccentric Plane*. The object is to determine the position of the center of pressure corresponding to different angles of inclination of a plane to the current. The method pursued both by Kummer and myself has been the one which most naturally suggests itself to find the angle of inclination a of the plane corresponding to a series of fixed distances d of the center of pressure from the center of figure. Thus in the experiments, d has been the independent variable, while in the use of the results, a is in general the independent variable.

For a square plane 90 mm. (3.54 inches) on the side, Kummer obtained the following results, which may be compared with the results given here in chapter VIII and with the formula of Joëssel :

Distance of center of pressure from center of plane.	Distance as a percentage of side of plane.	Angle of plane with current.
<i>mm.</i> 0	0.000	90°
1	0.011	84
2	0.022	77
3	0.033	70
4	0.044	62
5	0.056	52
6	0.067	41
7	0.078	31
8	0.089	28
9	0.100	26
10	0.111	25
13	0.144	21
14	0.156	19
15	0.167	18

* Mémorial du Génie Maritime, 1870.

† Berlin Akad-Abhandlungen, 1875, 1876.

In addition to determining the position of the center of pressure for a square plane, Kummer extended his experiments to the case of differently shaped rectangles, and his results with these are strikingly suggestive. It has been pointed out in chapter VI that above and below an angle of about 30° there is a reversal in the relative amounts of the pressure on inclined rectangular planes of different shapes; the tabulated results of Kummer exhibit a similar reversal in the position of the center of pressure, of which the following may be given as an example:

Distance of center of pressure from center of plane.

Size of plane.	Angles between plane and current.	
	45°.	10°.
<i>mm.</i> 180 x 180	<i>mm.</i> 11	<i>mm.</i> 40
90 x 180	14	36

For small angles the position of the center of pressure is further from the center of figure in the 180 x 180 mm. plane than in the 90 x 180 mm. plane, while for 45° this relation is reversed. It appears, therefore, that the reversal in the amount of pressure, brought out in the experiments presented in this memoir, finds its counterpart in a corresponding reversal in the position of the center of pressure exhibited in the work of Kummer. It is believed that in this striking analogy may be found a key to the more complete rational and deductive treatment of these inseparably related problems.



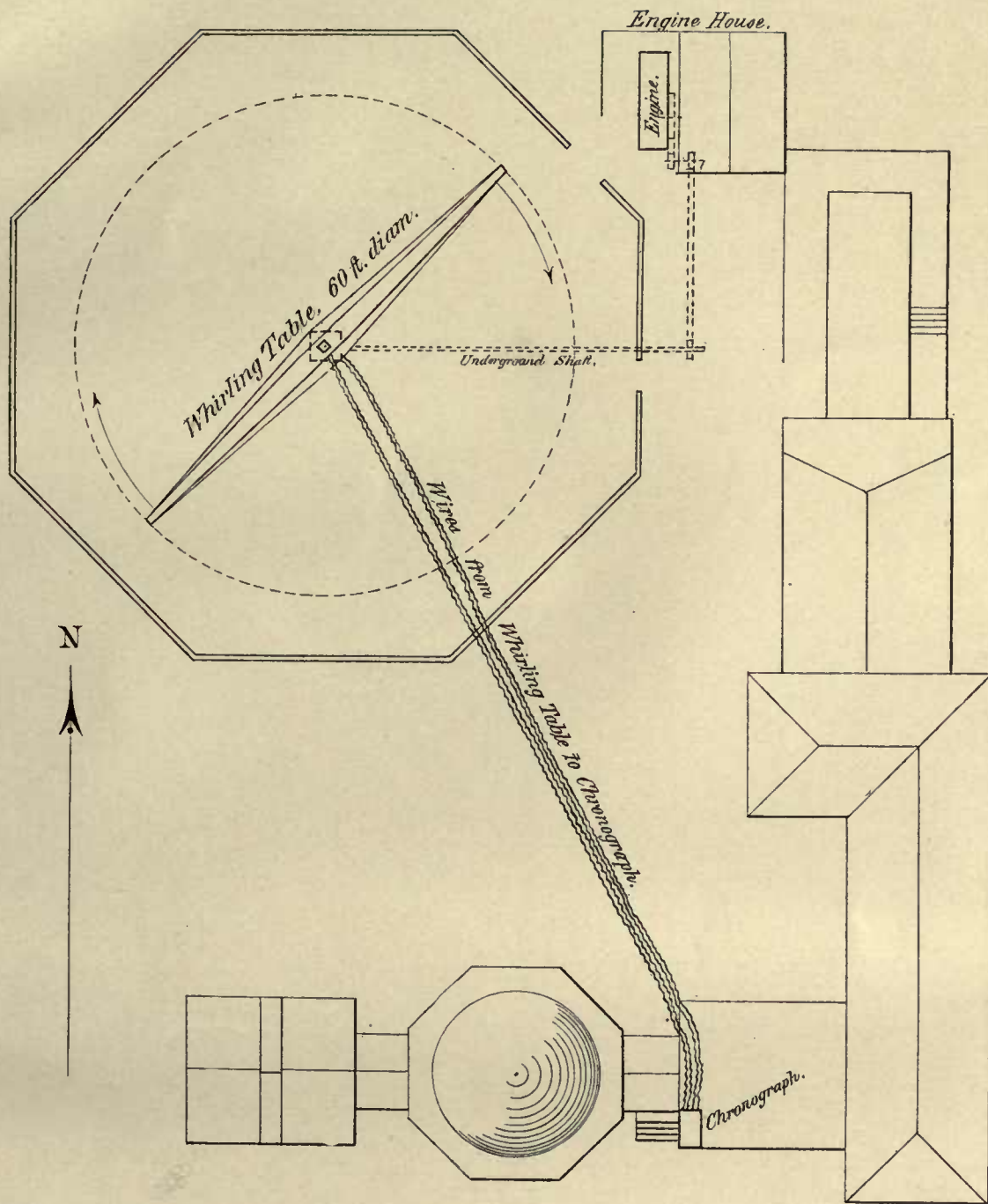

ALLEGHENY OBSERVATORY.

Plan of Grounds.

SCALE: 1 INCH = 20 FEET.





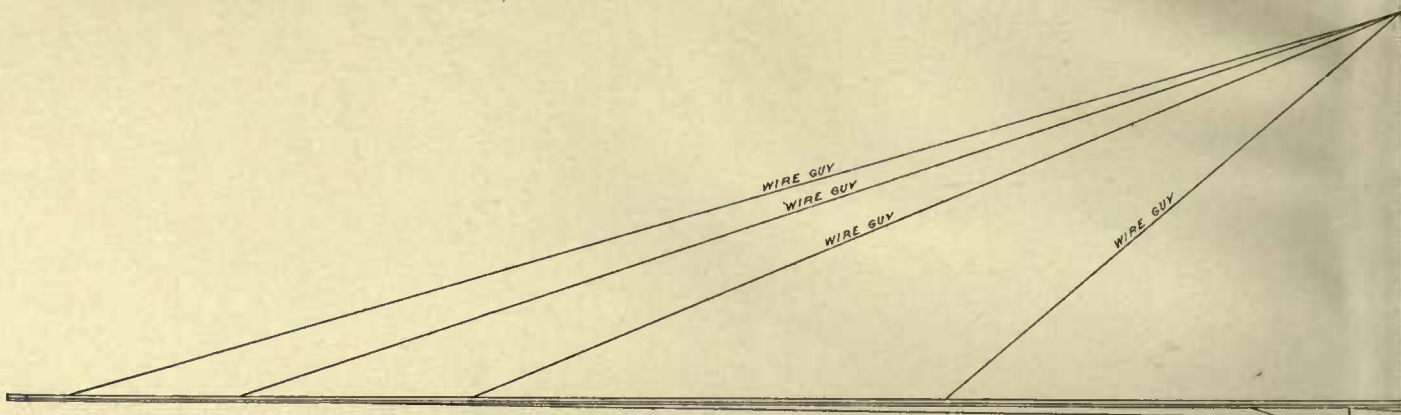

Electric Connections

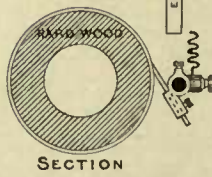
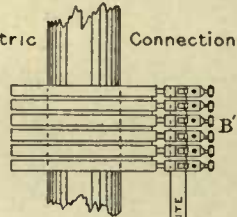

SECTION

SCALE



CROSS SECTION OF TABLE NEAR END.

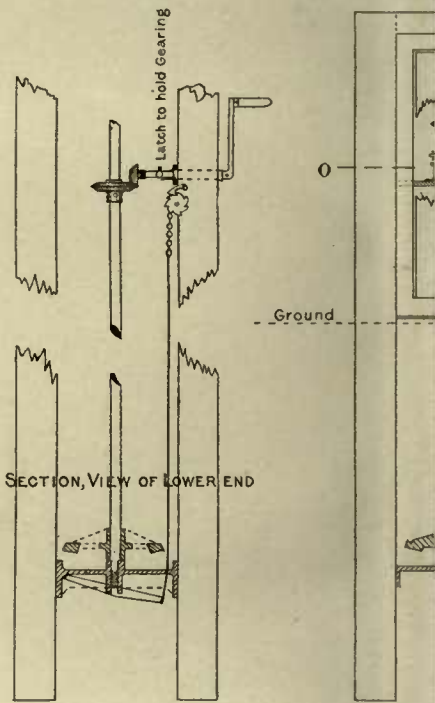
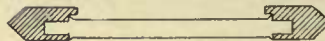

SECTION, VIEW OF LOWER END

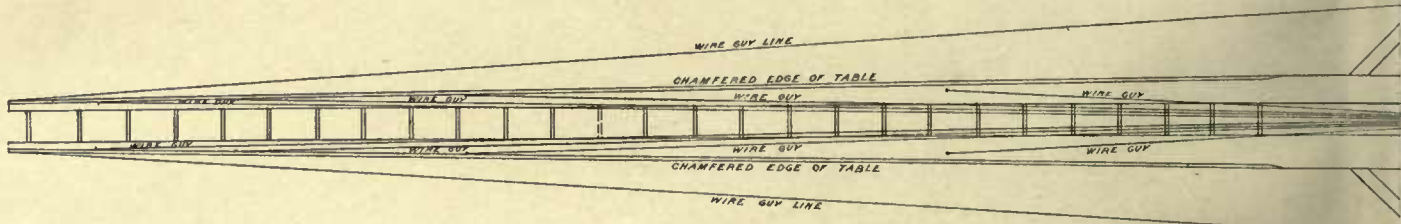

PLAN OF WH

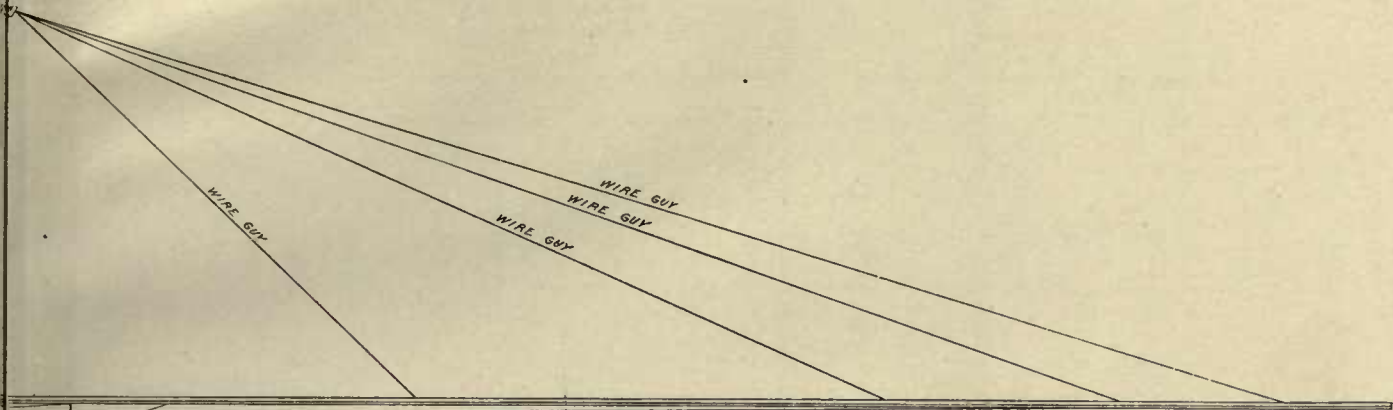

ELEVATION OF WHIRLING TABLE.

SCALE 0 2 4 5 FEET

Designed by S.P. LANGLEY.

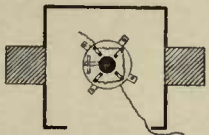

SECTION ON LINE O-P.

Under ground Shaft to Cones and Engine

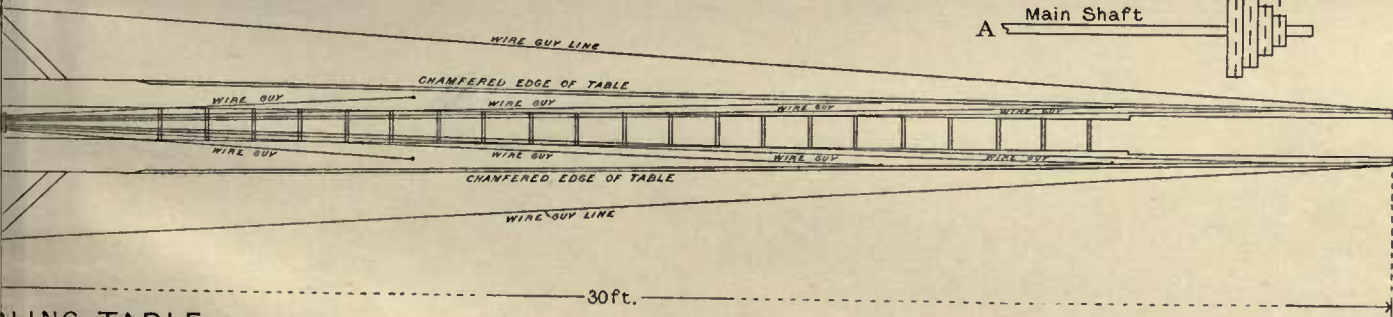
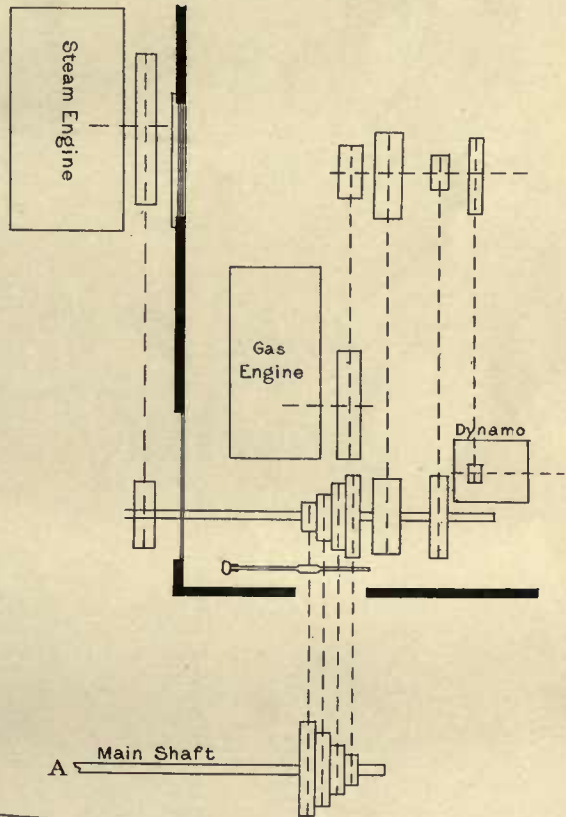
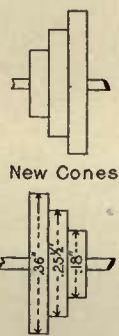

WHIRLING TABLE.



Designed by S.P. LANGLEY.

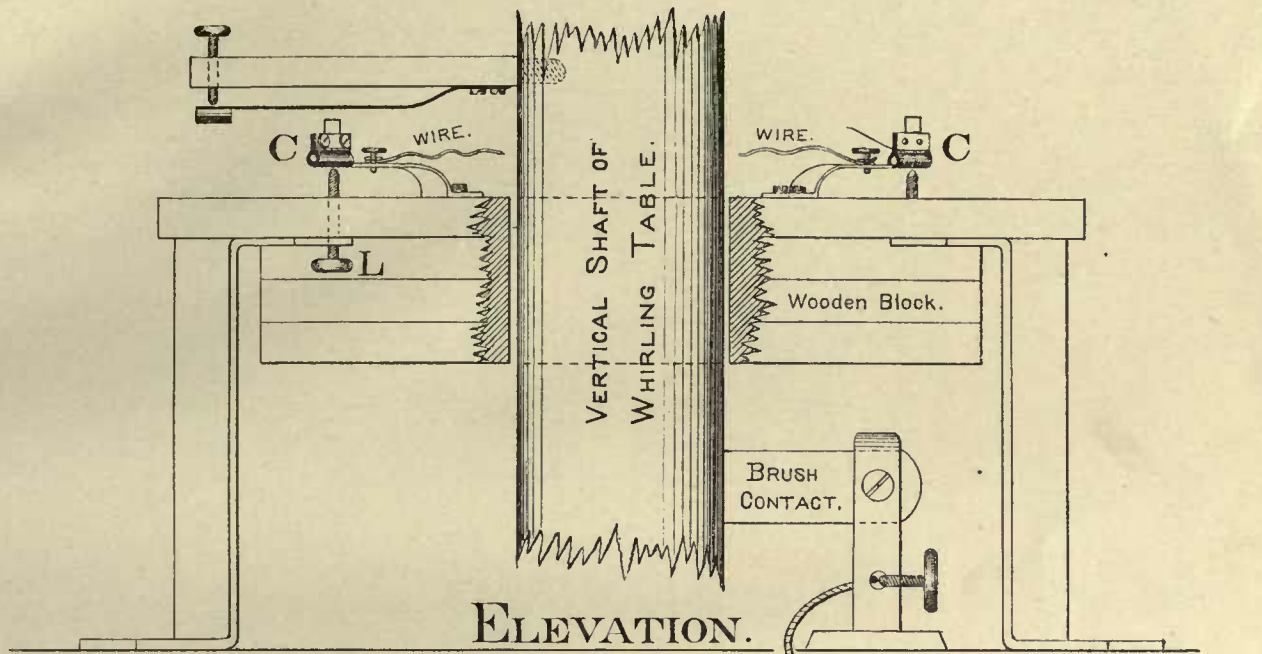

ELEVATION.

Wire through Underground Cable to Chronograph & Battery.

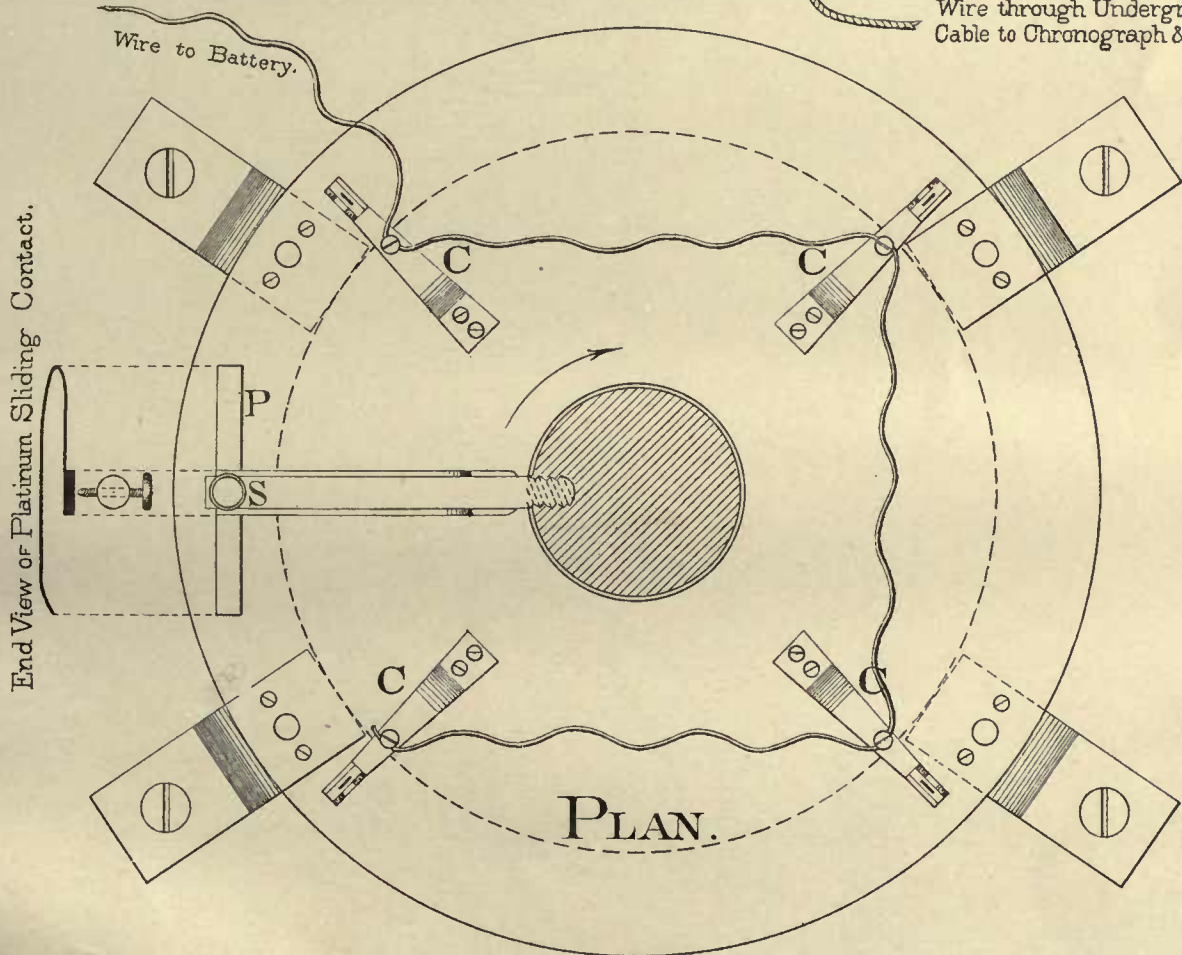

End View of Platinum Sliding Contact.

PLAN.

QUADRANT CONTACTS OF WHIRLING TABLE

SCALE 0 2 4 6 8 10 12 INCHES.



SUSPENDED PLANE.
SCALE. 0 2 4 6 8 10 12 INCHES.
Designed by S. P. LANGLEY.

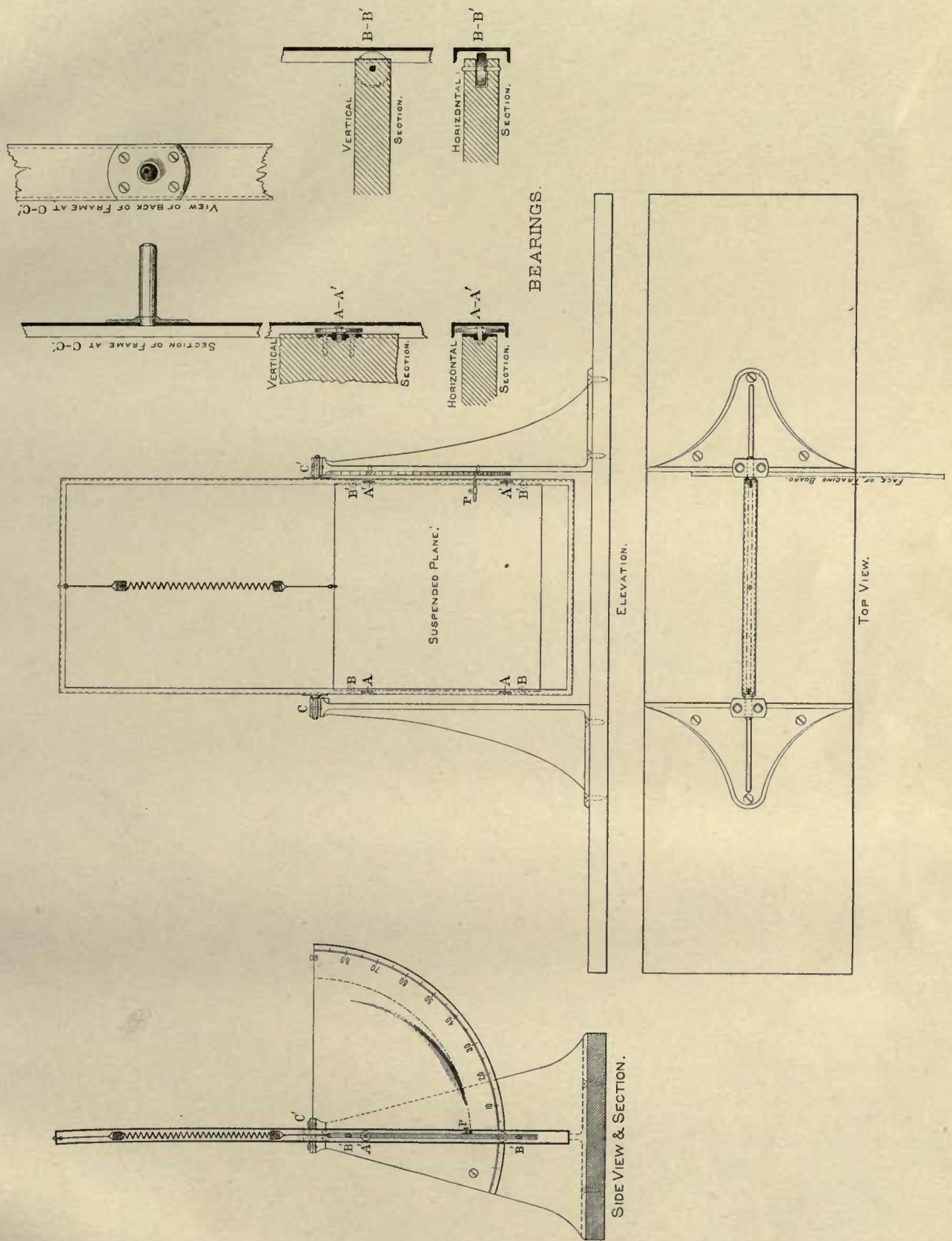



LIBRARY
OF THE
UNIVERSITY
OF
CALIFORNIA

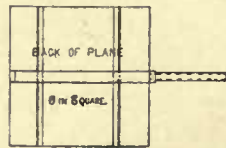
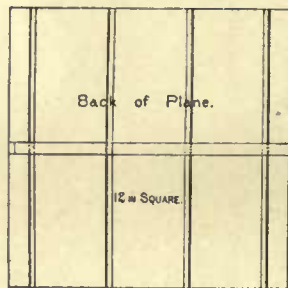
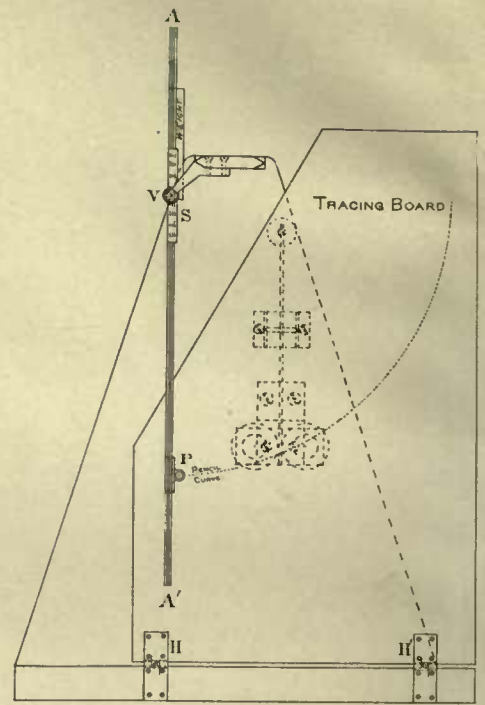

CLAMP

CIRCLE

A

A

ELEVATION.

R

TOP VIEW.



CROSS SECTION ON R-S.

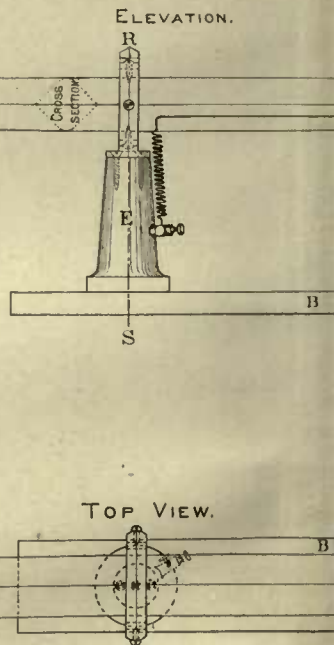

RESULTANT PRESSURE RECORDER

Designed by S.P. LANGLEY.

SCALE

INCHES 0 1 2 3 4 5 6 7 8 9 10

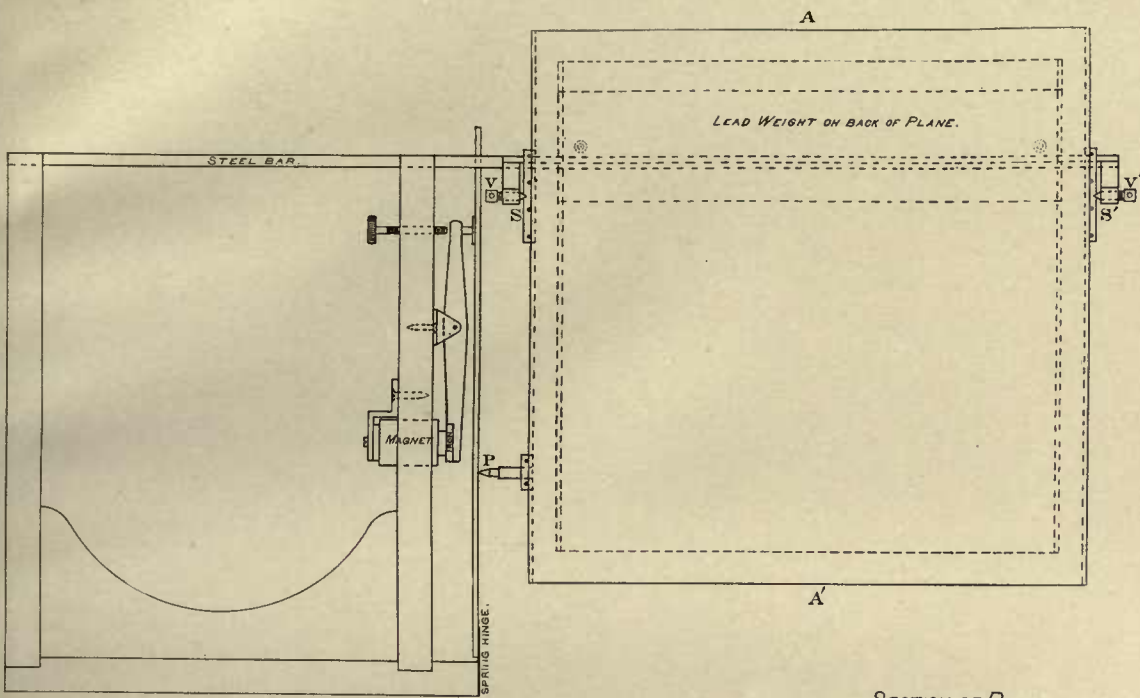

COUNTERPOISED ECCENTRIC PLANE.

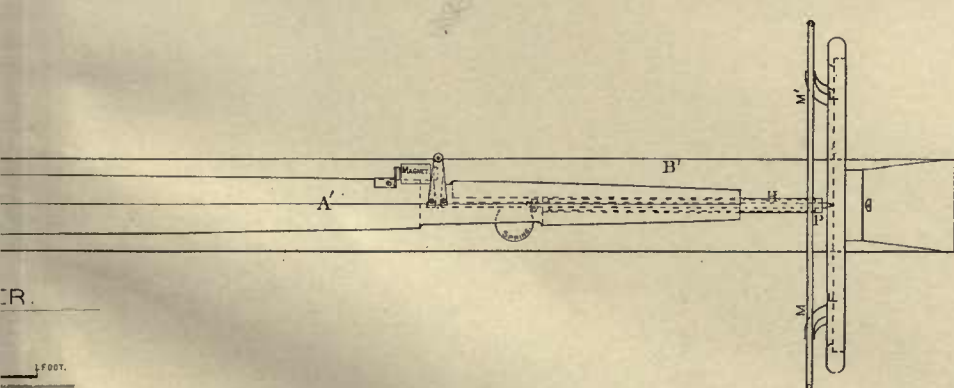
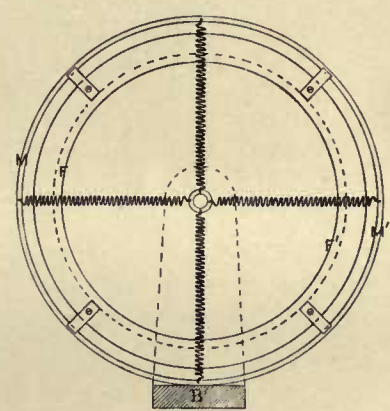
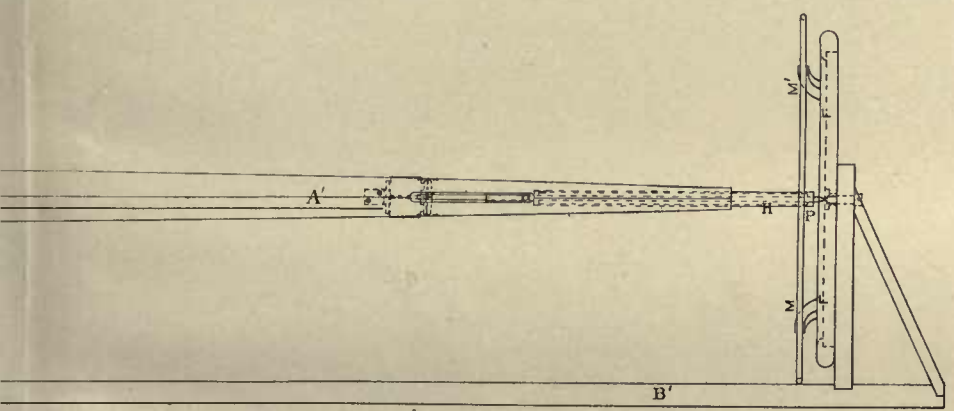
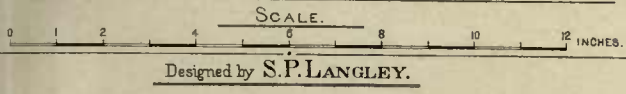

CR.

1 FOOT.

PLANE DROPPER.
Designed by S.P. LANGLEY.

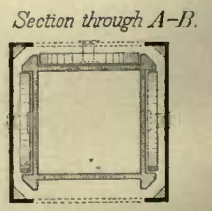
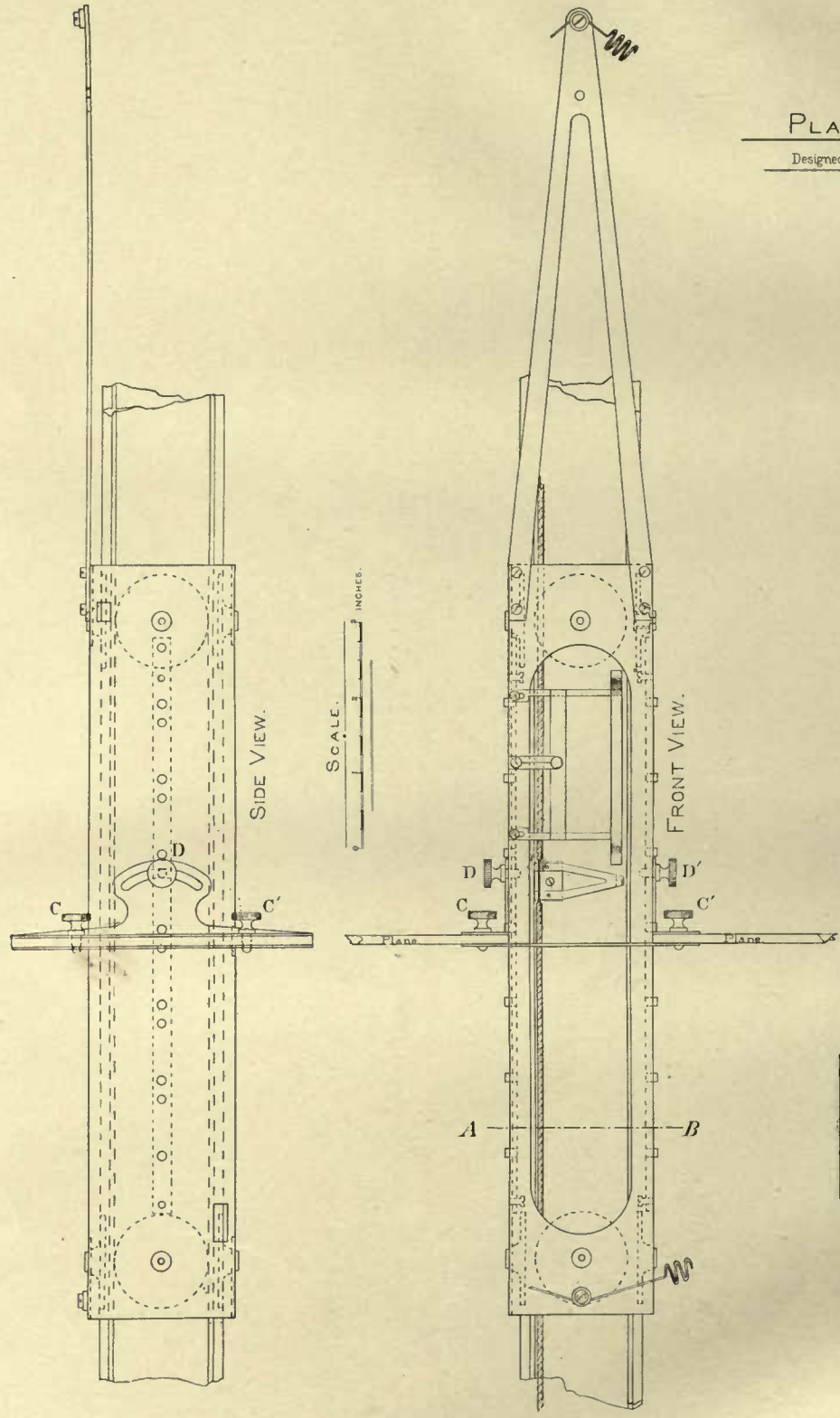
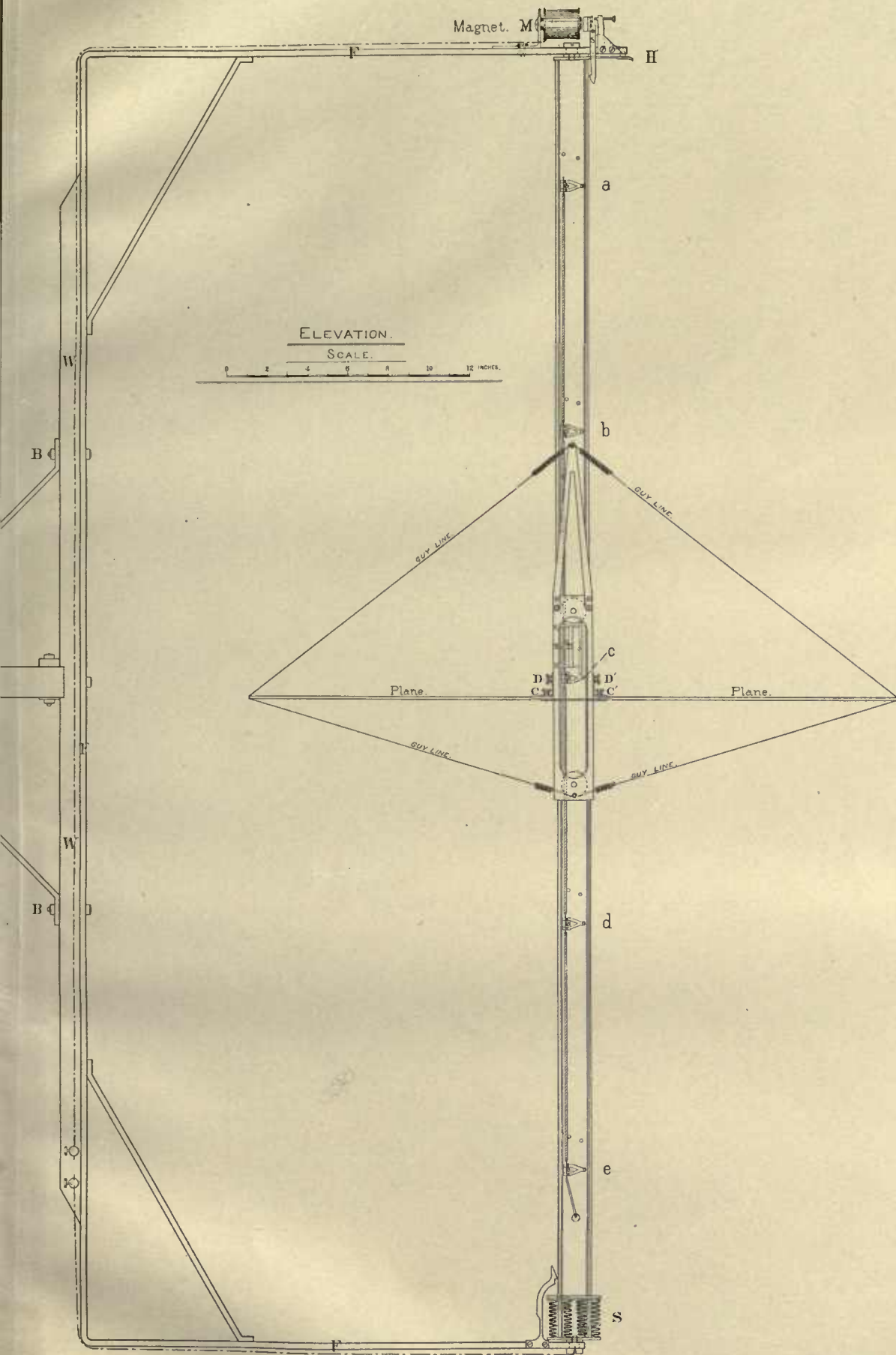

PLATE VI







COMPONENT PRESSURE P
 Designed by S.P. LANGR

SCALE.
 0 1 2 3 4 5 6 7 8 9

ELEVATION
 C

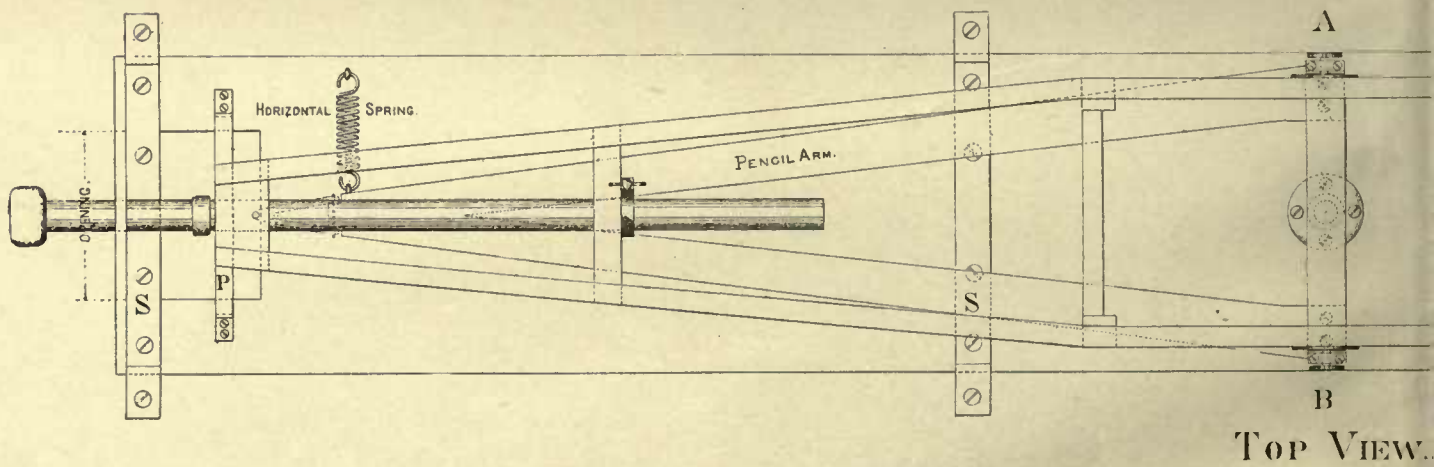
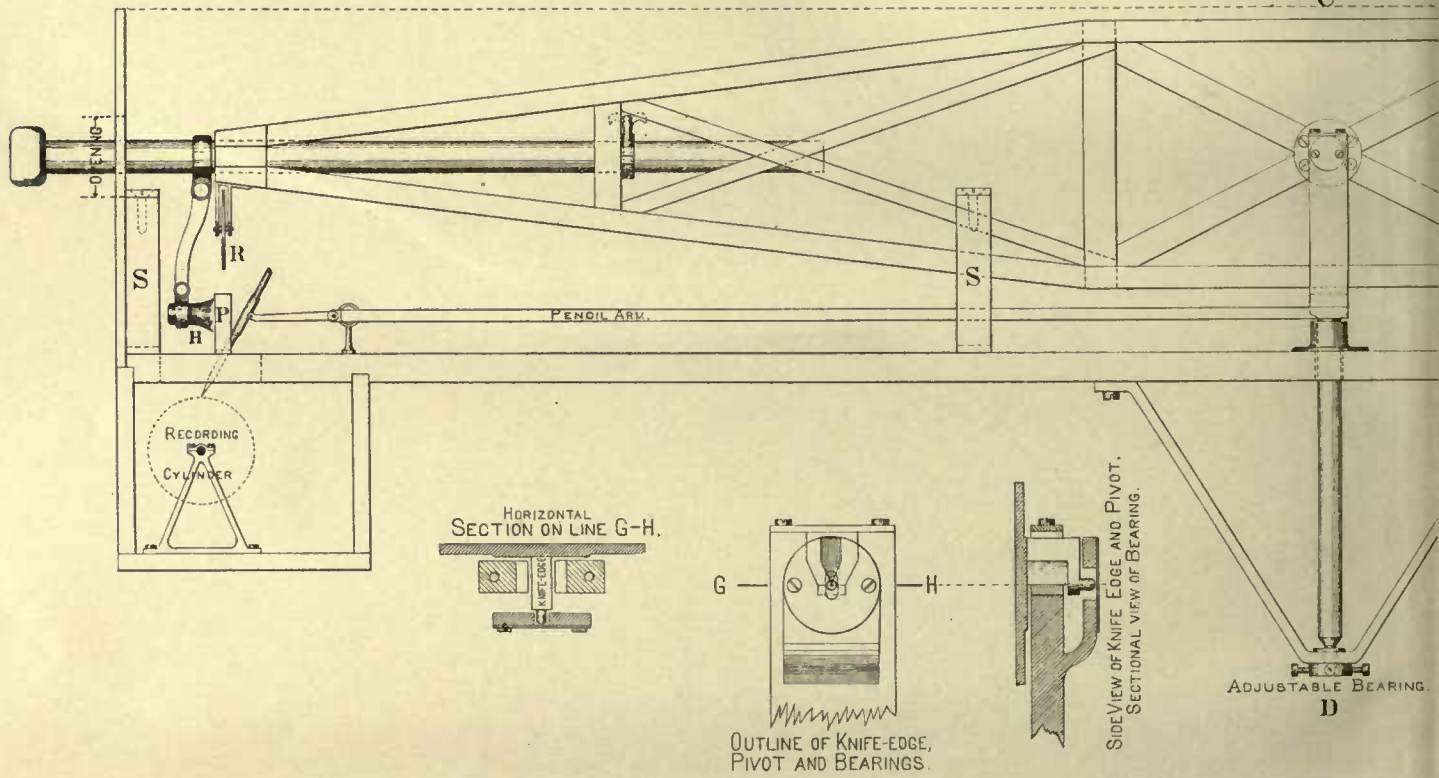
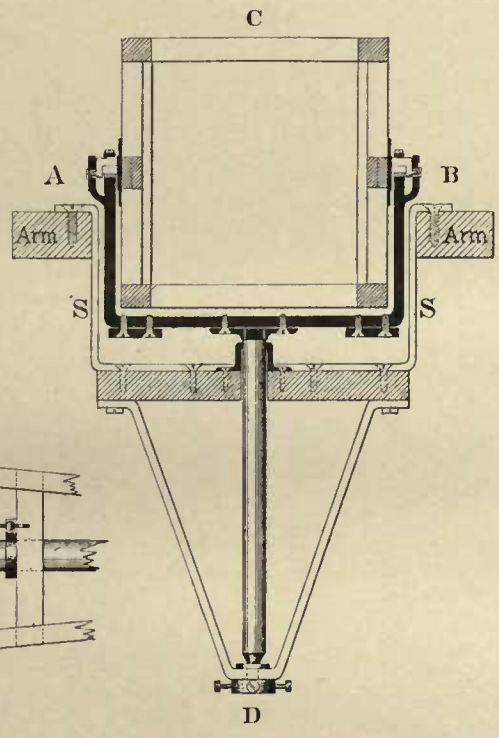
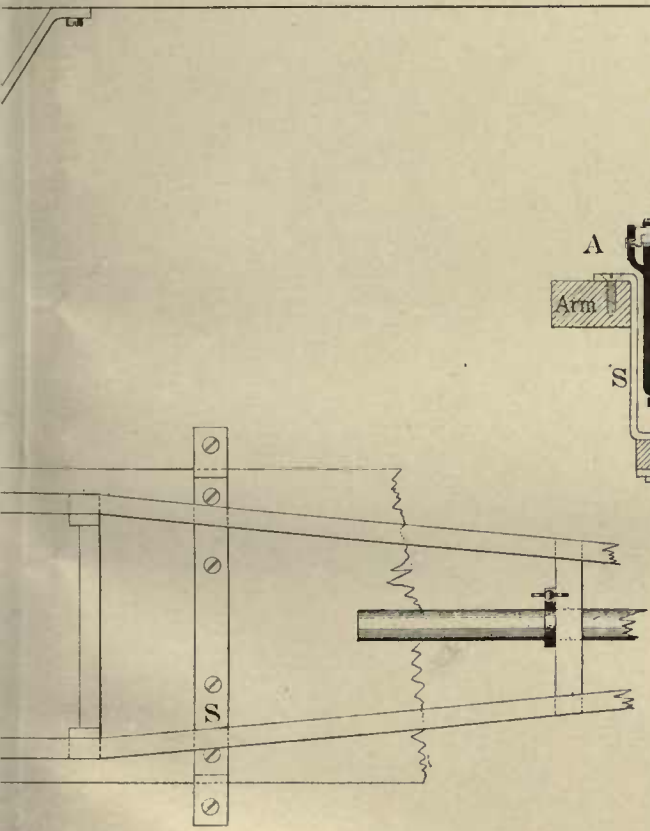
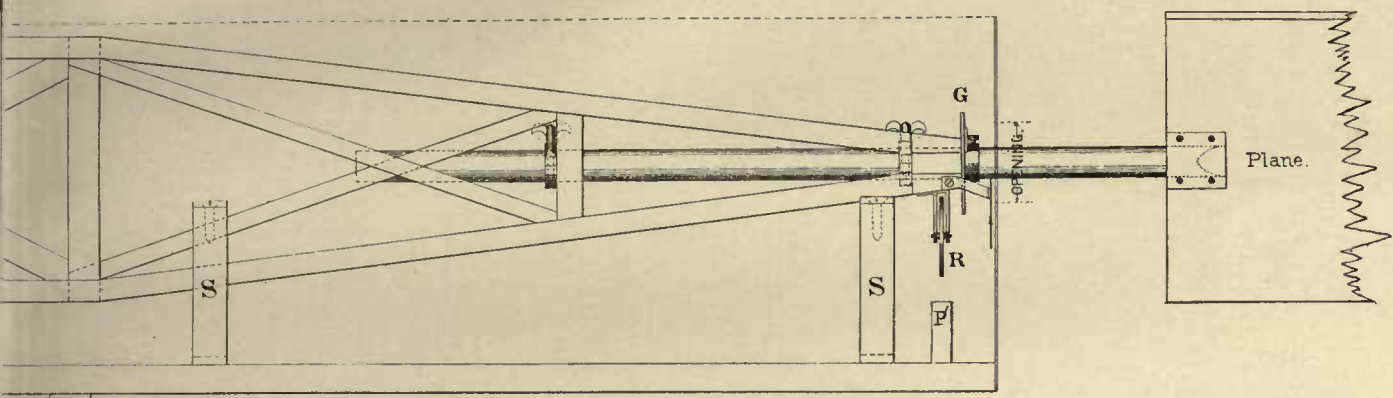

PLATE VII

BORDER.

1 1/2 INCHES







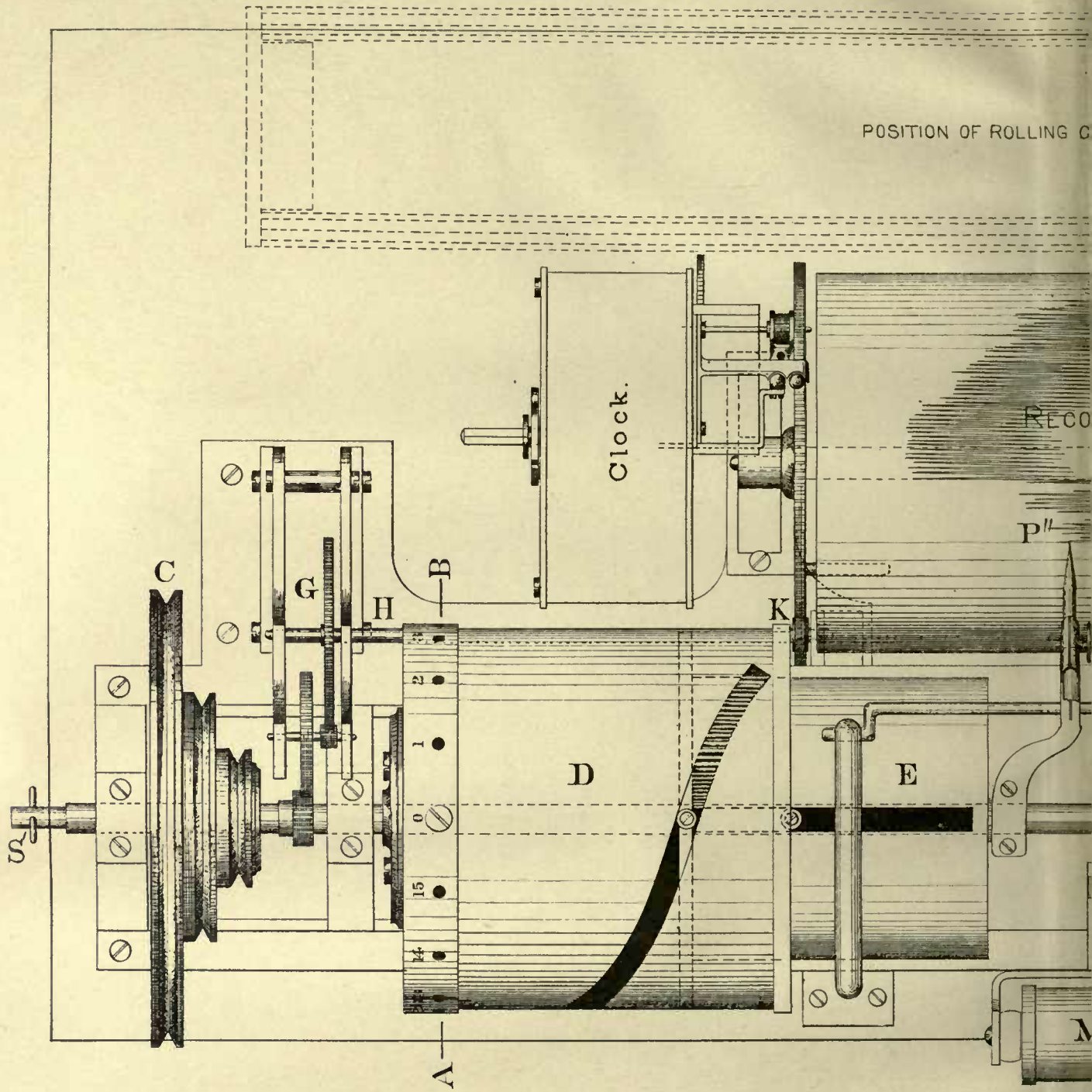

DYNAMOMETER

0 1 2 S

Des
S.P.L.

PLATE VIII

SECTION ON LINE A—B.

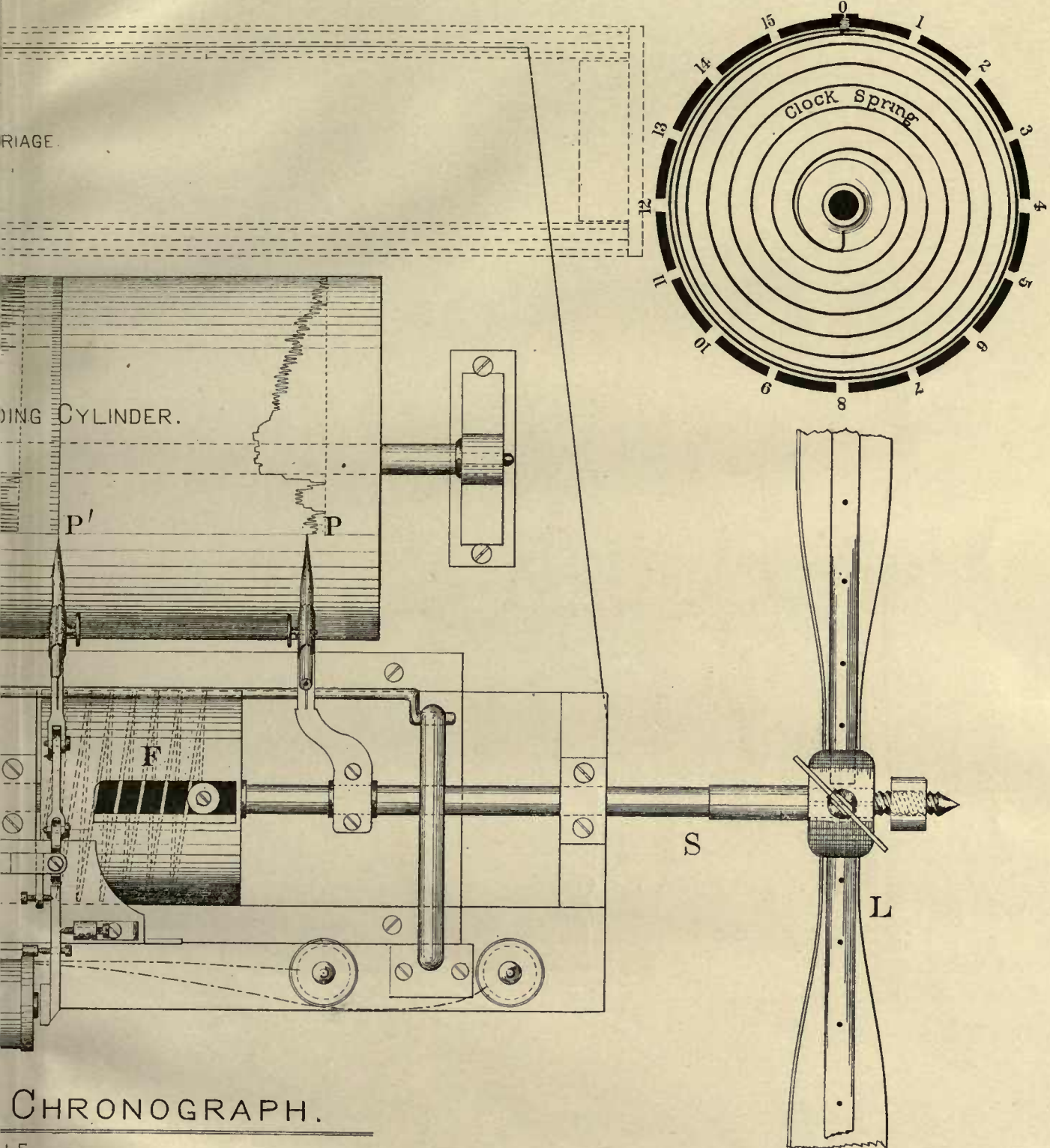

RIAGE.

ING CYLINDER.

CHRONOGRAPH.

LE. 4 5 6 INCHES.

d by GLEY.

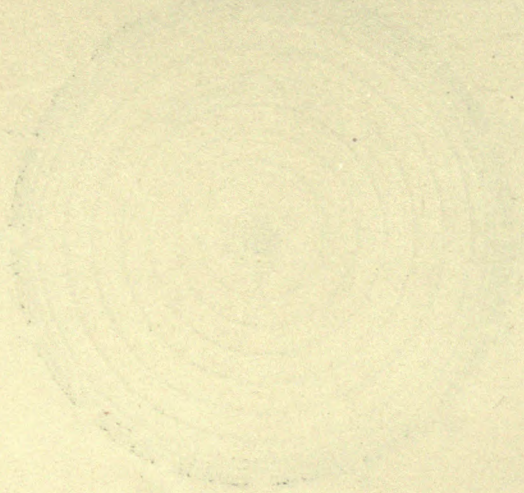

LIBRARY
OF THE
UNIVERSITY
OF
CALIFORNIA

LIBRARY
OF THE
UNIVERSITY
OF
CALIFORNIA

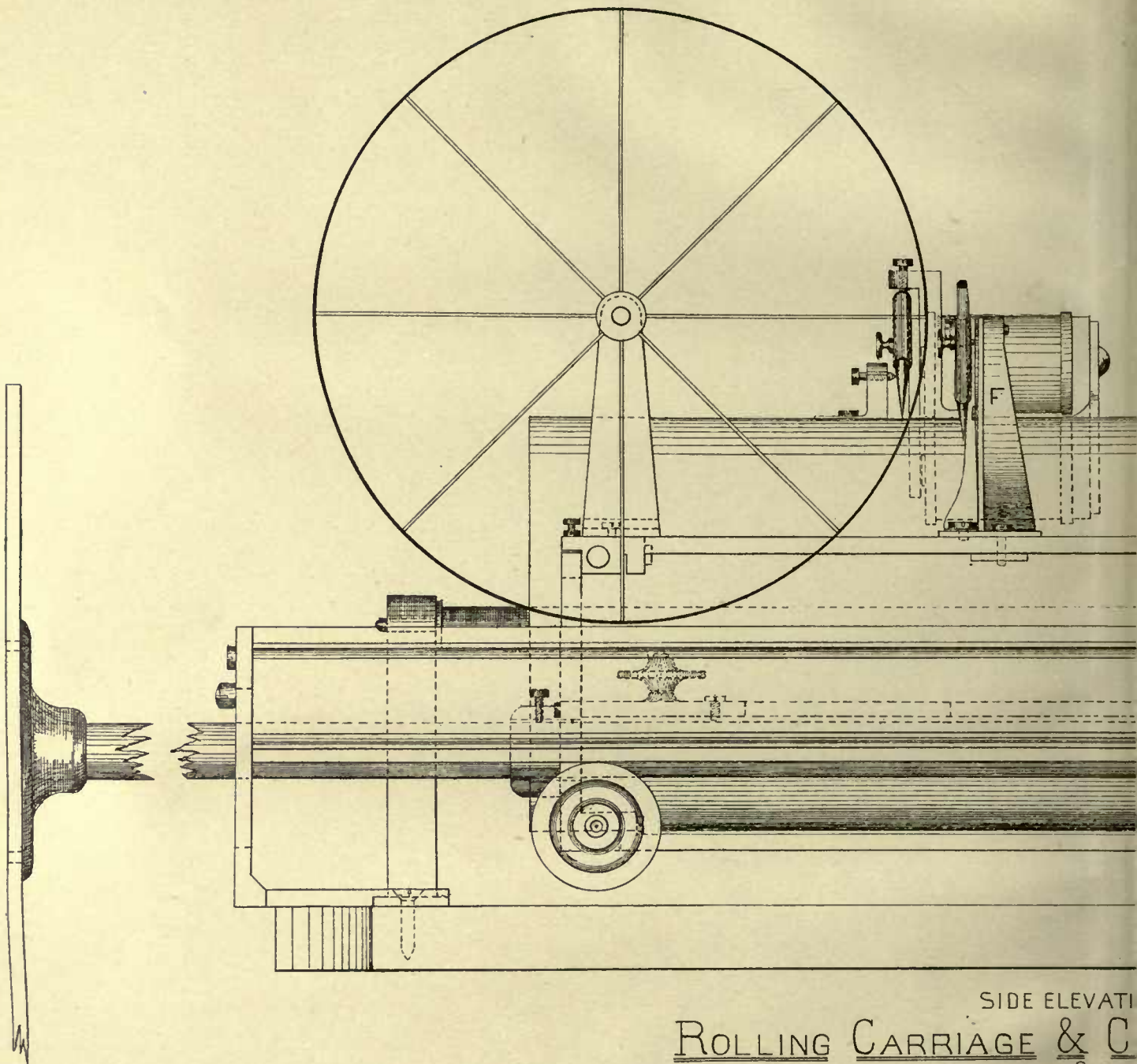

SIDE ELEVATION
ROLLING CARRIAGE & C

SCALE
INCHES. 0 1 2

Designed by S. F.

[Handwritten scribble]

PLATE IX

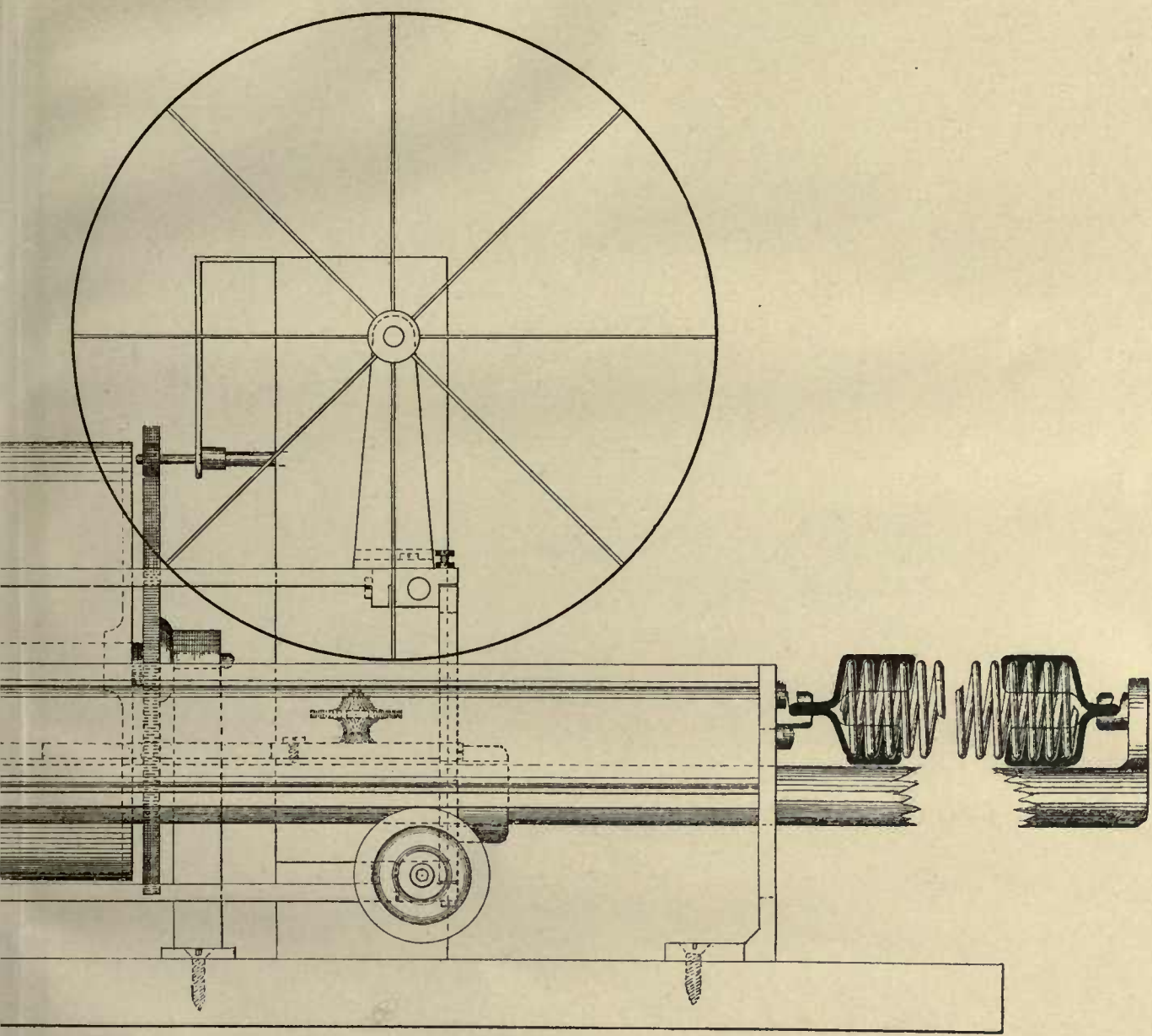

OF
CHRONOGRAPH BARREL.

LANGLEY.





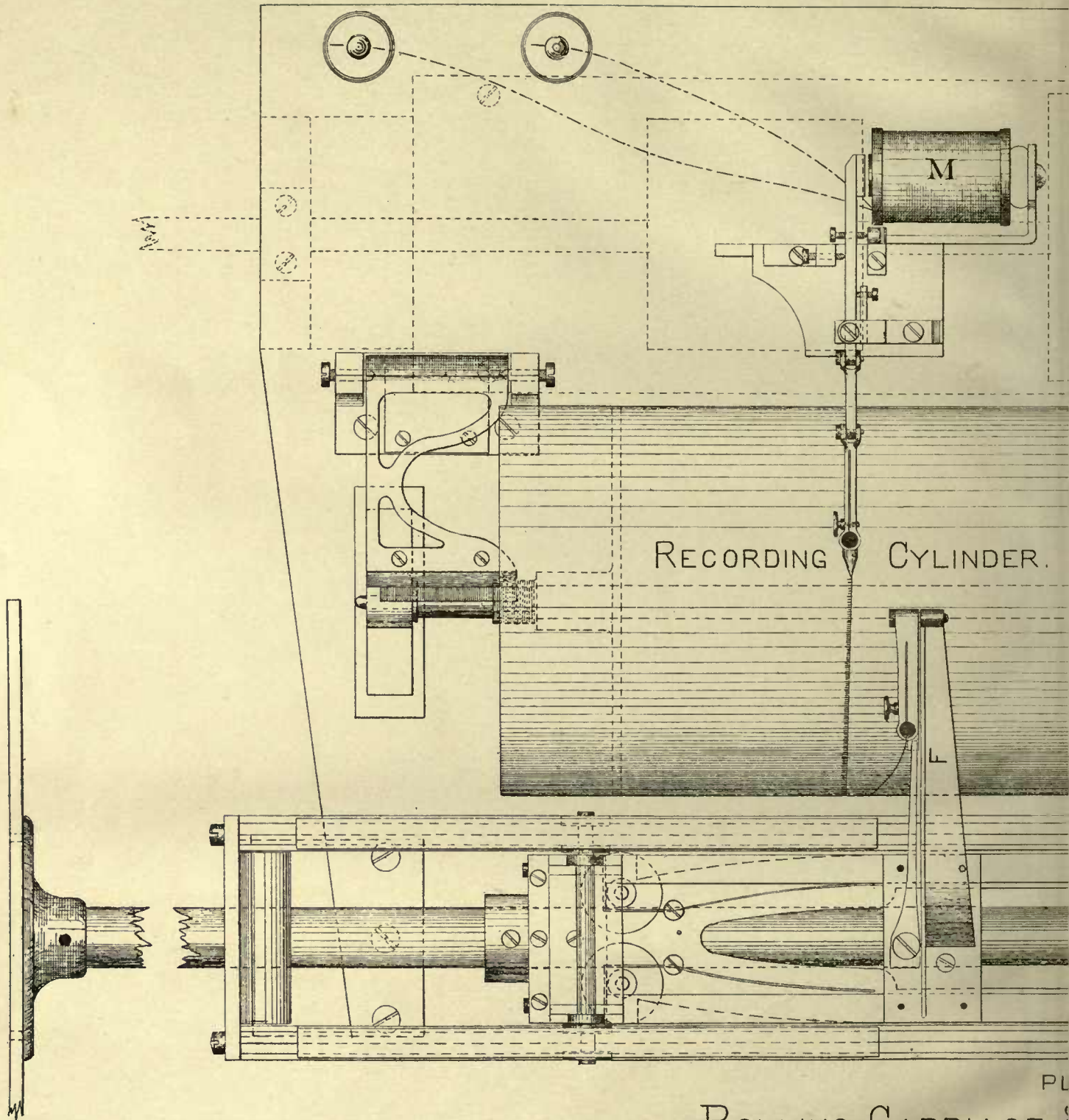

ROLLING CARRIAGE

INCHES 0 1 2

Designed by

27

PLATE X

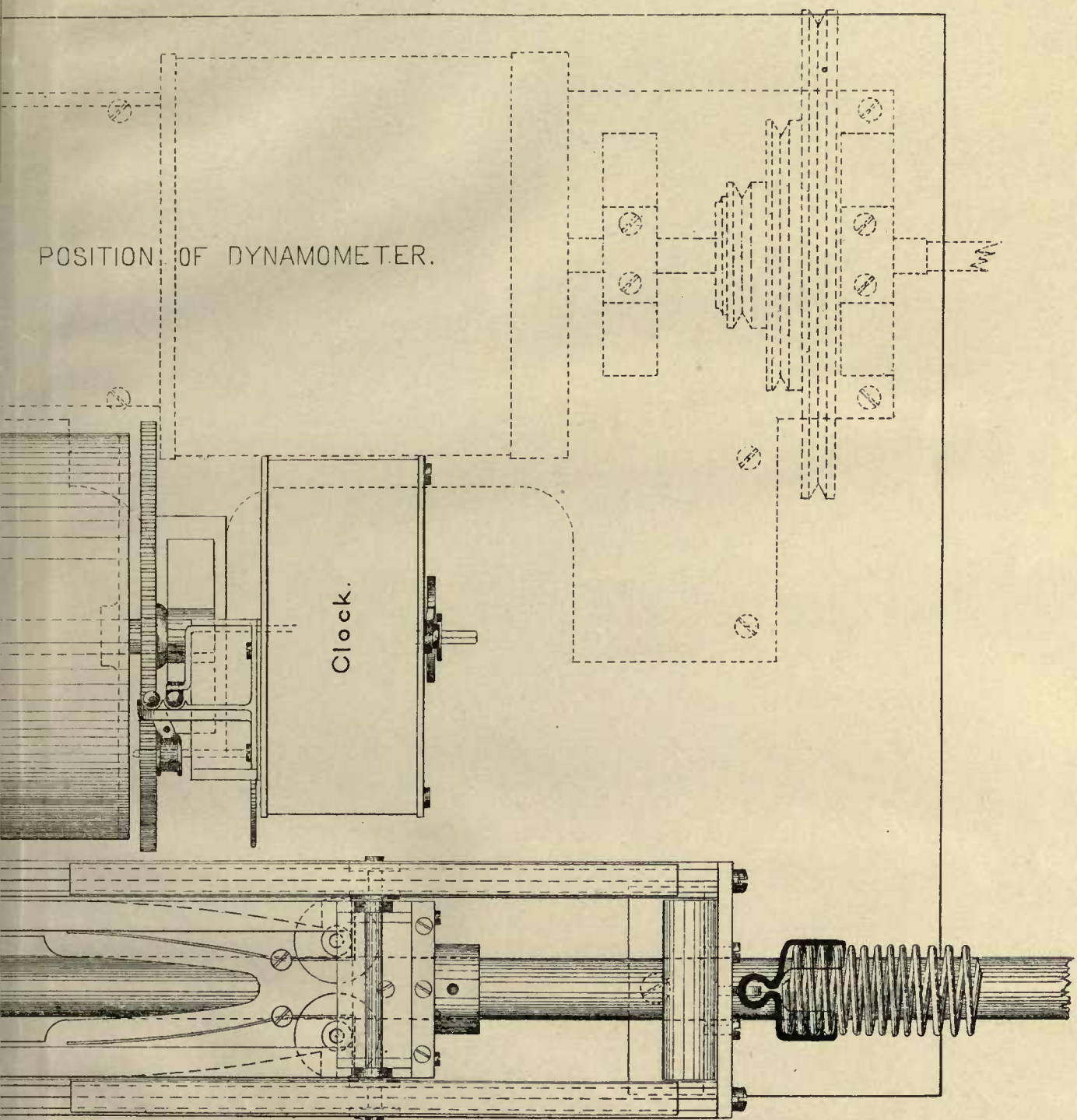

SECTION OF
CHRONOGRAPH BARREL.



S. P. LANGLEY.



14 DAY USE
RETURN TO DESK FROM WHICH BORROWED

LOAN DEPT.

This book is due on the last date stamped below, or
on the date to which renewed.

Renewed books are subject to immediate recall.

6 Feb '61 LF	
REC'D LD	
JAN 22 1961	
16 May '62 SR	
REC'D LD	
MAY 15 1962	
INTERLIBRARY LOAN	
JAN 4 1984	
UNIV. OF CALIF., BERK.	
Received in Interlibrary Loan	
Received in Interlibrary Loan	
10 1984	
LD 21A-50m-4,'60 (A9562s10)476B	General Library University of California Berkeley

11/6/07

YH 00528



